

SQRE4T15B IGNITION SYSTEM

GENERAL INFORMATION	14-3	ON-VEHICLE SERVICE	14-7
Overview	14-3	Ignition Coil Assembly	14-7
Description	14-3	Removal	14-7
Operation	14-4	Ignition Circuit	14-8
Specifications	14-4	Inspection	14-9
Tool	14-4	Installation	14-9
DIAGNOSIS & TESTING	14-5	Spark Plug	14-10
Diagnosis Content	14-5	Removal	14-10
Problem Symptoms Table	14-5	Inspection	14-10
Service precautions	14-6	Spark Jump Test Method	14-11
		Spark Plug Common Problems	14-11
		Installation	14-13

دیجیتال خودرو

شرکت دیجیتال خودرو سامانه (مسئولیت محدود)

اولین سامانه دیجیتال تعمیرکاران خودرو در ایران



دیجیتال خودرو

شرکت دیجیتال خودرو سامانه (مسئولیت محدود)

14

اولین سامانه دیجیتال تعمیرکاران خودرو در ایران



GENERAL INFORMATION

Overview

Description



IG0001001

1 - Spark Plug	2 - Cylinder 4 Ignition Coil Assembly
3 - Cylinder 3 Ignition Coil Assembly	4 - Cylinder 2 Ignition Coil Assembly
5 - Cylinder 1 Ignition Coil Assembly	

14-SQRE4T15B IGNITION SYSTEM

Operation

- Ignition system mainly consists of sensors, Engine Control Module (ECM), ignition coils, spark plugs, etc. Ignition advance angle is controlled by Engine Control Module (ECM) directly.
- As an integrated module, the ignition coil cannot be disassembled. SQRE4T15B uses independent ignition system. The secondary high-voltage terminal of each ignition coil is connected to spark plug in engine cylinder via high-voltage connecting rod. Ignition coil primary low-voltage terminal connects to Engine Control Module (ECM) via wire harness.
- Engine Control Module (ECM) receives the Top Dead Center (TDC) position of each cylinder piston via input signal of phase sensor, and uses the speed sensor signal to make ignition coil to operate.

Specifications

Torque Specifications

Description	Torque (N·m)
Spark Plug	20 ± 3
Ignition Coil Fixing Bolt	8 ± 2

Spark Plug Specifications

Description	Specifications
Engine Type	SQRE4T15B
Spark Plug Type	3707AAG
Spark Plug Gap (mm)	0.7 - 0.8

Tool

General Tool

14

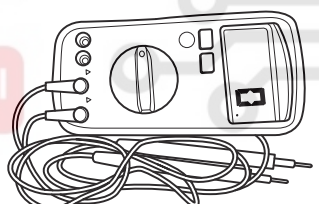
<p>شرکت دیجیتال خودرو سامانه (مسئولیت محدود)</p> <p>اولین سامانه دیجیتال تعمیرکاران خودرو در ایران</p> <p>Digital Multimeter</p>	 <p>002</p>
--	---

DIAGNOSIS & TESTING

Diagnosis Content

Problem Symptoms Table

Hint:

Use symptoms table below to help determine cause of problem. Check each suspected area in sequence. Repair, replace or adjust faulty components as necessary.

Symptom	Suspected Area
Stall	Ignition coil and high-voltage cable
	Camshaft position sensor
	Spark plug
	Intake camshaft phaser control valve
	Exhaust camshaft phaser control valve
	Wire harness
	ECU
Knock	Ignition coil and ignition high-voltage cable
	Knock sensor
	ECU
Difficult to start	Battery
	Ignition coil and high-voltage cable
	Spark plug
	Engine speed sensor
Engine hesitation, power drop, unstable performance	Ignition coil and high-voltage cable
	Engine speed sensor
	Intake camshaft phaser control valve
	Exhaust camshaft phaser control valve
	Spark plug
	Camshaft position sensor
Rough, unstable idling or stall	ECU
	Ignition coil and high-voltage cable
	Camshaft position sensor
	Spark plug
	ECU

14–SQRE4T15B IGNITION SYSTEM**Service precautions**

Visual inspection can reduce the unnecessary test and diagnostic time, so pay attention to the following inspection items:

1. Check the line and hose for obvious looseness, and if they are disconnected or routed improperly.
2. Make sure that the battery connections are clean and fixed firmly.
3. Check if the generator wire and belt are installed correctly and securely.
4. Check if the engine wire harness connectors are inserted fully.
5. Check if all electrical connectors are installed correctly and securely.
6. Check the following electrical connections
 - (a) Engine speed sensor
 - (b) Oxygen sensor
 - (c) Intake pressure/temperature sensor
 - (d) Oil pressure switch
 - (e) Ignition coil
 - (f) Canister solenoid valve
 - (g) Camshaft position sensor
 - (h) Electronic throttle
 - (i) Intake Variable Valve Timing (VVT) control valve
 - (j) Exhaust Variable Valve Timing (VVT) control valve
 - (k) Fuel injector
7. Check the routing of all vacuum hoses.
8. Confirm that the following vacuum hoses are connected securely without any leakage
 - (a) Canister solenoid valve
 - (b) PCV valve
 - (c) Brake booster
9. Check the fuel pump hose and wire connection to make sure that they are connected securely.

ON-VEHICLE SERVICE

Ignition Coil Assembly

Removal

Warning/Caution/Hint

Caution:

- Be sure to wear necessary safety equipment to prevent accidents when repairing.
- Try to prevent body paint surface from being scratched during removal and installation.
- It is prohibited to use short circuit spark test to test ignition function during repair, otherwise it may damage the module.
- During using, do not remove ignition coil from spark plug with bare hands with power on, and do not contact the metal part and rubber guide rod directly, to avoid electric shock.

1. Turn off all electrical equipment and the ignition switch.
2. Disconnect the negative battery cable.
3. Remove the engine trim cover.
4. Remove the ignition coil.

- (a) Disconnect the ignition coil connectors (1), and move away the wire harness from ignition coil.

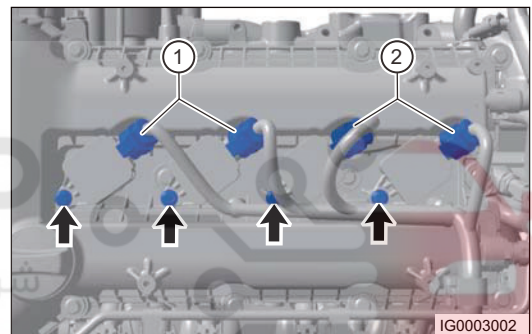

- (b) Disconnect ignition coil connectors (2), and move away wire harness from ignition coil.

- (c) Remove 4 fixing bolts (arrow) from ignition coil.

Tightening torque

$8 \pm 2 \text{ N}\cdot\text{m}$

14-SQRE4T15B IGNITION SYSTEM

Ignition Circuit

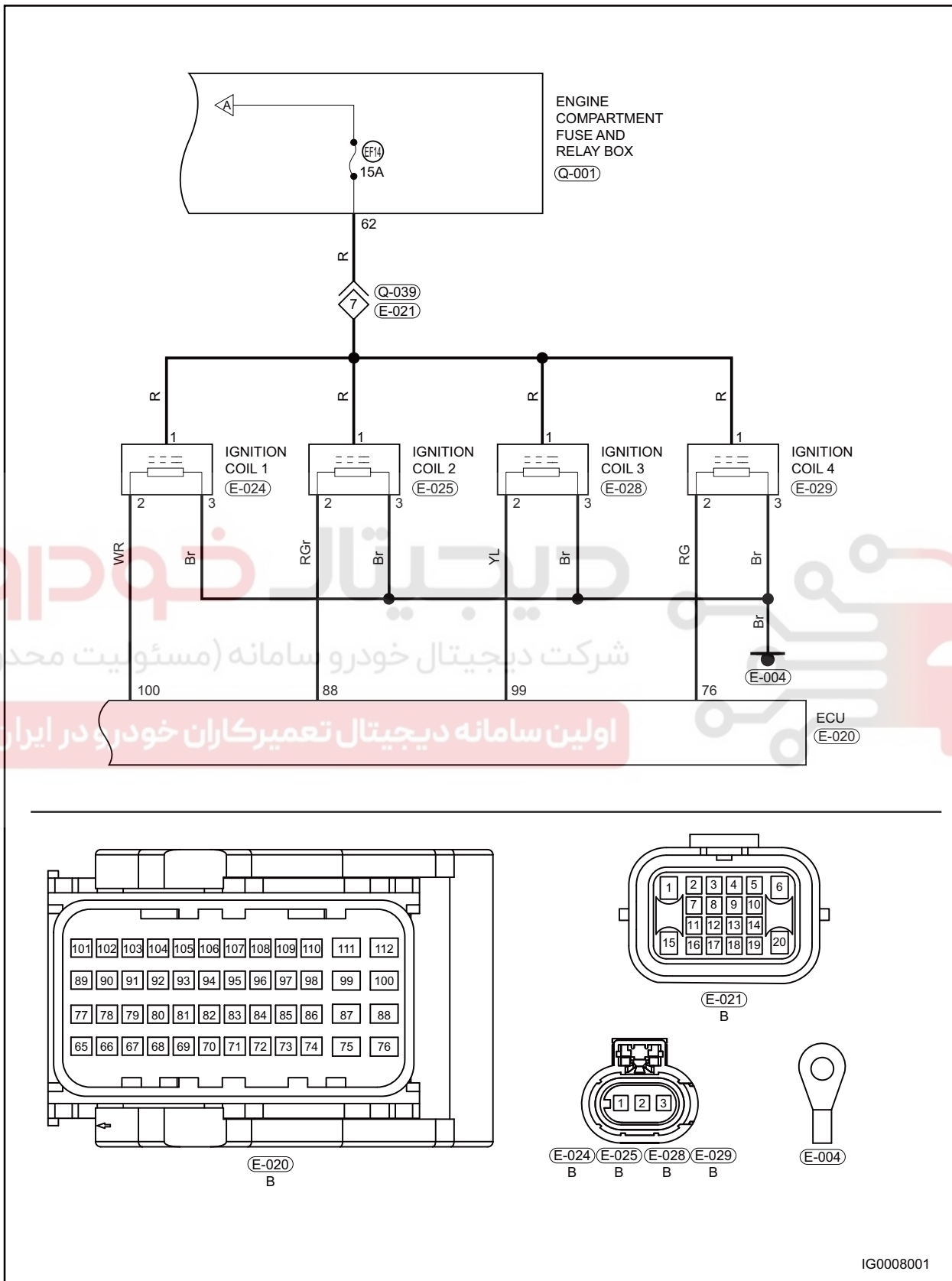

Inspection

1. Inspect the resistance of ignition coil primary winding.
 - (a) Turn digital multimeter to ohm band, and check the resistance between terminals 1 and 2.

Terminal	Terminal Definition
1	Power Supply
2	Control Signal
3	Ground

Multimeter Connection	Condition	Specification (Ω)
Terminal 1 - Terminal 2	Normal temperature	0.5 - 0.64

Hint:

If result is not as specified, replace ignition coil.

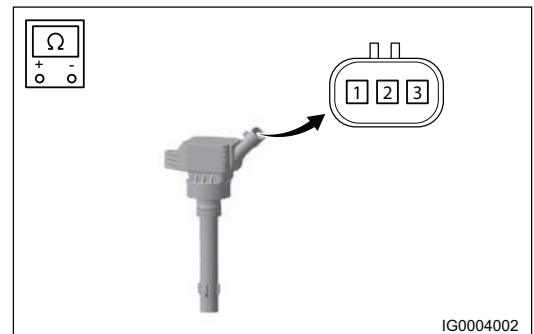

Installation

1. Installation is in the reverse order of removal.

Caution:

- Make sure that the connection of ignition coil high-voltage output terminal and spark plug is reliable, or it may cause high-voltage leakage, resulting in poor ignition.
- Inspect cylinder head spark plug mounting hole before installation and foreign matter are prohibited during assembling.
- Install the ignition coil into cylinder head cover mounting hole and press it to close to mounting boss on cylinder head cover. Never turn ignition coil to left/right after pressing and do not tap ignition coil with a hammer etc.

شرکت دیجیتال خودرو سامانه (تسویه محدود)

اولین سامانه دیجیتال تعمیرکاران خودرو در ایران

14-SQRE4T15B IGNITION SYSTEM

Spark Plug

Removal

Warning/Caution/Hint

Caution:

- Be sure to wear necessary safety equipment to prevent accidents when repairing.
- Try to prevent body paint surface from being scratched during removal and installation.
- DO NOT remove the spark plugs when engine is hot; failure to do this may cause damage to the spark plug thread holes on cylinder head.
- Before removal, remove the dirt and foreign matter around spark plug holes to prevent them from dropping into cylinders.

1. Turn off all electrical equipment and the ignition switch. Wait until engine cools down and then perform removal to avoid "sliding wire" with hot engine.
2. Disconnect the negative battery cable.
3. Remove the engine trim cover assembly.
4. Remove the ignition coil.
5. Remove the spark plug

- (a) Using a special spark plug socket ratchet wrench (1), loosen the spark plug.

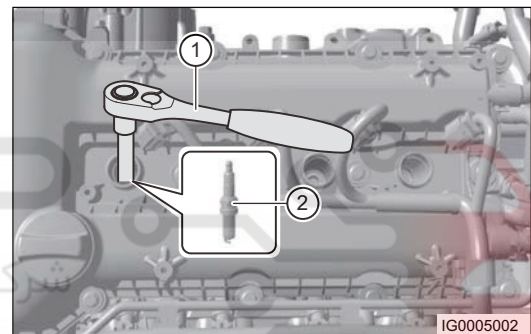

- (b) Remove the spark plug (2).

Inspection

1. Check the spark plug gap.
 - (a) Check the spark plug gap a: 0.7 - 0.8 mm.

Hint:
It is not necessary to adjust the gap.

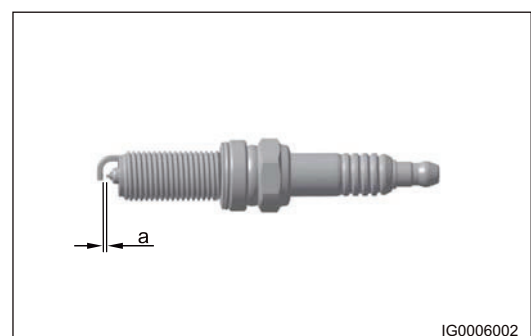

Spark Jump Test Method

1. Remove the spark plug from engine and connect it to high-voltage cable, put the spark plug case 5 - 7 mm away from engine body and start vehicle to check the spark jump.

Warning:

- Always disconnect the injector circuit before test to avoid injection during spark jump test.

- (a) If there is a thick spark with blue-white color and popping occurs between spark plug and engine body and also spark generated between center electrode and side electrode, that indicates ignition system is normal.

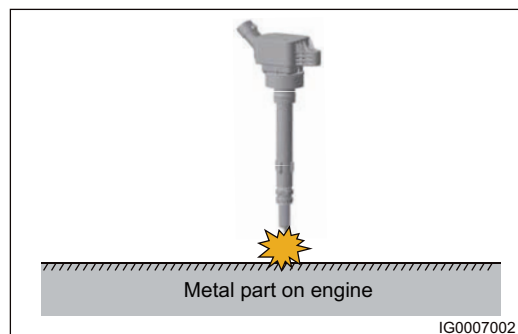

- (b) If there is a thick spark with blue-white color between spark plug and engine body and no spark between center electrode and side electrode, but spark is in inside of center electrode, that indicates inside of spark plug is damaged.
- (c) If the spark is red and short or there is no spark, check ignition coil or others.

Spark Plug Common Problems

Normal

- Spark plug porcelain small end is between white and yellowish, gray or brownish.
- Air-fuel ratio and ignition time are normal, there is no misfire, and cold-start enriching function is normal.
- There are no fuel or oil deposits.

Carbon Accumulation

A layer of velvety black charcoal smoke attaches on the insulator small end, motor and spark plug body		
Cause	Result	Treatment
Mixture is excessively rich due to improper adjustment of air fuel mixture.	Poor starting ability	Adjust air-fuel ratio and cold starting system, and check air filter.
Traveling distance of vehicle is too short (at high gear and low speed), engine temperature is low, and combustion is incomplete.		
Fuel quality is poor or fuel deteriorates, combustion is incomplete.		
Spark plug type is incorrect.		

14-SQRE4T15B IGNITION SYSTEM

Oil Dirt

A layer of black oily charcoal smoke and dirt attach on the insulator small end, motor and spark plug body		
Cause	Result	Treatment
Piston ring has bad elasticity or is worn excessively, and oil breaks into combustion chamber.	Difficult to start	Check and repair engine, or replace spark plug.
Excessive matching clearance between piston skirt and cylinder wall causes oil breaking and air leakage.		
Air leakage occurs due to incorrect installation of piston ring in direction of inside and outside tangent angle, causing oil breaking into combustion chamber.		
Excessive clearance occurs between valve stem and valve guide due to excessive wear, or valve guide oil seal fails, causing oil leakage.		
Oil level is too high and oil breaks into combustion chamber.		

Lead Deposits

Brownish yellow enamels or greenish deposits exist on the insulator small end		
Cause	Result	Treatment
The fuel additive contains lead, when engine runs under high load conditions with throttle partially opened for a long time, enamel is formed.	Causing misfire	Replace spark plug.

Lead Deposits

There are severe dust deposits from oil additives on the insulator small end, even on the entire insulator skirt and electrode; there are loose cinder deposits on spark plug and combustion chamber		
Cause	Result	Treatment
Additives, especially the oil additives, can form these dust deposits in spark plug and combustion chamber.	Causing misfire, resulting in power loss or engine damage	Check and repair engine, replace spark plug or change oil type.

Red deposits

There are severe red brown deposits on insulator skirt and electrodes, and clear radial discharge traces can be seen on the surface of insulator small end		
Cause	Result	Treatment
In the unleaded gasoline, Mn-based anti-riot agent MMT is used instead of lead tetraethyl, the oxide of Mn after combustion adheres on the surface of insulator and electrode.	At high temperature, these deposits are easily conductive, resulting in flashover on insulator skirt surface, unstable combustion, high engine speed, and jitter under heavy load conditions.	Use qualified fuel, replace spark plug.

Melting on center electrode

Electrode melts, insulator small end softens, expands, and becomes sponge-like		
Cause	Result	Treatment
Overheating caused by self-ignition, excessively large ignition advance angle, deposits in combustion chamber, valve damage, inferior fuel, incorrect spark plug type.	A misfire, power loss or engine damage.	Check engine, ignition, injection and air intake system, and install spark plug with correct type

14–SQRE4T15B IGNITION SYSTEM

Serious Burn in Side Electrode

Serious burn in side electrode		
Cause	Result	Treatment
Corrosive fuel and oil additives, deposits or other factors affect the way of air flowing in combustion chamber, engine knocking without overheating.	A misfire, especially a misfire during acceleration (ignition voltage is insufficient to break through the severely increased electrode gap), it is difficult to start.	Replace spark plug.

Damage on Insulator Small End

Damage on insulator small end		
Cause	Result	Treatment
Mechanical damage (center electrode is stressed due to hitting, dropping, or incorrect handling), caused by severe expansion of deposits between insulator and center electrode or severe corrosion of center electrode.	A misfire, spark occurs at the damage point.	Replace spark plug.

Flashover on Insulator Surface

There is obvious arc burning trace on porcelain surface in axial direction		
Cause	Result	Treatment
Long time use of spark plug, excessive gap, excessive ignition voltage, high-voltage cable jacket aging, poor insulation performance, excessive clearance between high-voltage cable jacket and porcelain.	Spark plug cannot jump properly.	Replace high-voltage cable. Or apply silicone oil to high-voltage cable and replace spark plug.

Cracks on Insulator Big End

Cracks on insulator big end		
Cause	Result	Treatment
Mechanical action, caused by hitting, dropping or use of incorrect handling tool	Mechanical damage, electrode cannot jump normally.	Replace spark plug.

Installation

Warning/Caution/Hint

Caution:

- Check the spark plug type to confirm if it is suitable.
- Please install spark plug with a special spark plug socket, and never damage the normal spark plug gap.
- Avoid to install the spark plug from higher position from mounting hole during installation to prevent spark plug side electrode gap from damaging, resulting in poor ignition.
- Always tighten the spark plug according to specified torque using a torque wrench when installing and replacing it.

1. Install the spark plug.
 - (a) Install 4 spark plugs respectively into the cylinder head mounting holes for pre-tightening, and then retighten the spark plugs with a torque wrench.

Tightening torque

20 ± 3 N·m

2. Other installation procedures are in the reverse order of removal.

- MEMO -

دیجیتال خودرو

شرکت دیجیتال خودرو سامانه (مسئولیت محدود)

اولین سامانه دیجیتال تعمیرکاران خودرو در ایران

