

AXLE

GENERAL INFORMATION	22-3	Removal	22-15
Description	22-3	Installation	22-16
Specifications	22-5	Front Sub Frame Welding Assembly	22-17
Tools	22-6	Removal	22-17
DIAGNOSIS & TESTING	22-8	Installation	22-19
Problem Symptoms Table	22-8	Rear Hub Bearing Assembly	22-20
ON-VEHICLE SERVICE	22-9	On-vehicle Inspection	22-20
Front Steering Knuckle	22-9	Removal	22-21
Removal	22-9	Installation	22-21
Disassembly	22-11	Rear Hub Shaft	22-22
Inspection	22-12	Removal	22-22
Assembly	22-12	Installation	22-23
Installation	22-13	Rear Shaft Assembly	22-24
Front Hub Assembly	22-14	Removal	22-24
On-vehicle Inspection	22-14	Installation	22-25

دیجیتال خودرو

شرکت دیجیتال خودرو سامانه (مسئولیت محدود)

اولین سامانه دیجیتال تعمیرکاران خودرو در ایران



021 62 99 92 92

www.digitalkhodro.com

دیجیتال خودرو

شرکت دیجیتال خودرو سامانه (مسئولیت محدود)

اولین سامانه دیجیتال تعمیرکاران خودرو در ایران



021 62 99 92 92

www.digitalkhodro.com

GENERAL INFORMATION

Description

Front Axle

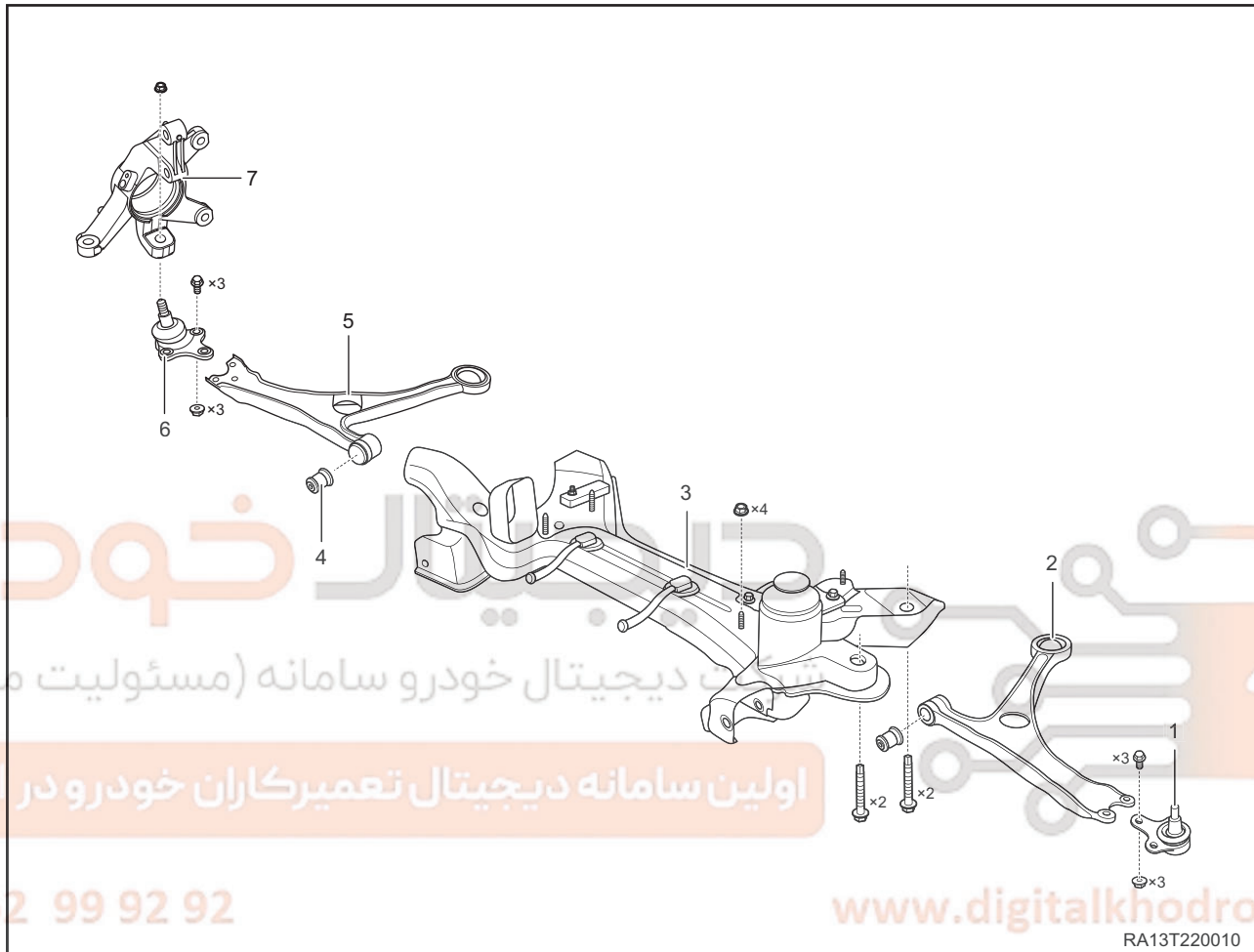

1 - Front Left Control Arm Ball Pin Assembly	2 - Front Left Control Arm Assembly
3 - Front Sub Frame Welding Assembly	4 - Rubber Bushing
5 - Front Right Control Arm Assembly	6 - Front Right Control Arm Ball Pin Assembly
7 - Front Right Steering Knuckle	

22 - AXLE

Rear Axle

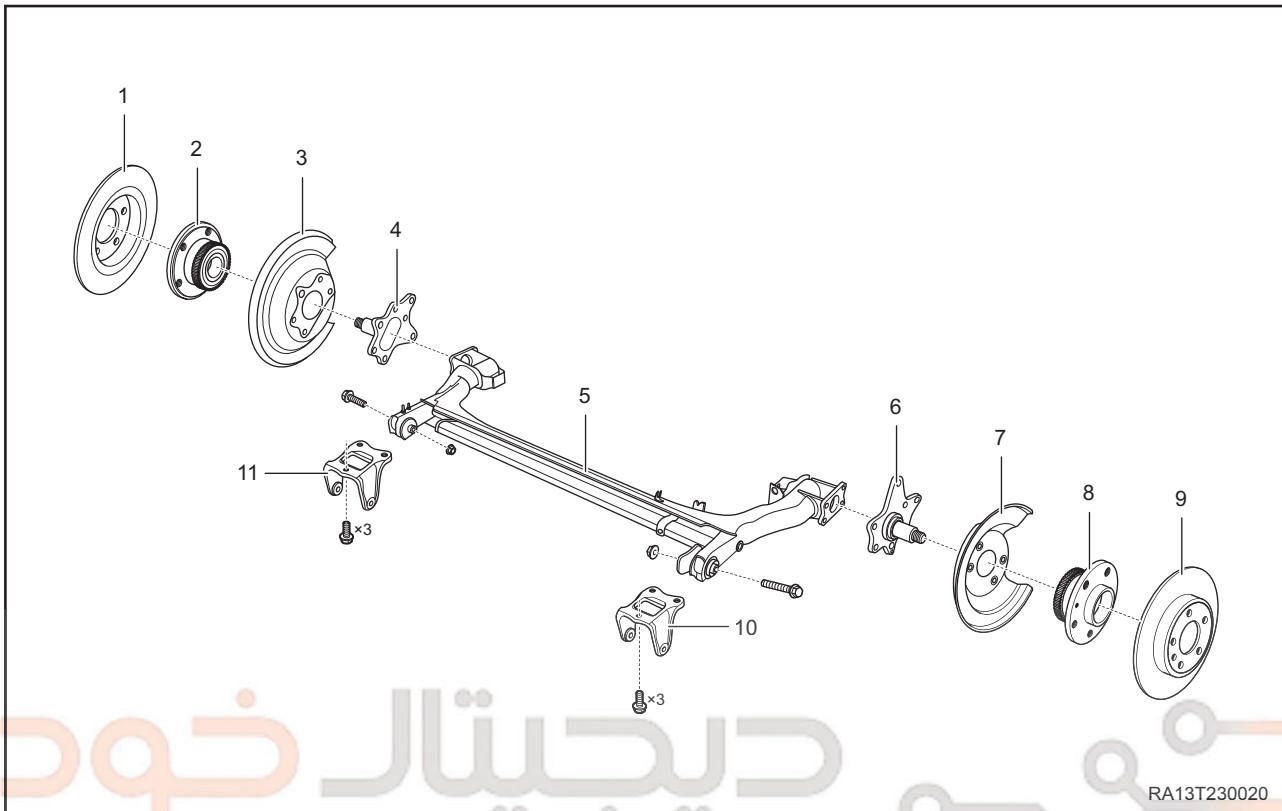

RA13T230020

1 - Rear Right Brake Disc	2 - Rear Right Hub Bearing
3 - Rear Right Brake Bottom Plate Assembly	4 - Rear Right Hub Shaft
5 - Rear Shaft Assembly	6 - Rear Left Hub Shaft
7 - Rear Left Brake Bottom Plate Assembly	8 - Rear Left Hub Bearing
9 - Rear Left Brake Disc	10 - Rear Left Shaft Bracket Assembly
11 - Rear Right Shaft Bracket Assembly	

Axles are connected to the integral body through suspensions, and wheels are installed at both ends. Its function is to transmit force in all directions between integral body and wheels.

Specifications

Torque Specifications

Description	Torque (N·m)
Wheel Mounting Bolt	110 ± 10
Front Drive Shaft Assembly Locking Nut	330 ± 20
Fixing Bolt Between Front Dust Guard and Front Steering Knuckle Assembly	9 ± 11
Coupling Bolt Between Front Wheel Speed Sensor and Front Steering Knuckle Assembly	10 ± 1
Self-locking Nut Between Steering Tie Rod Assembly Ball Pin and Front Steering Knuckle Assembly	35 ± 3
Coupling Nut Between Front Control Arm Assembly Ball Pin and Front Steering Knuckle Assembly	100 ± 10
Coupling Bolt Between Front Shock Absorber Assembly and Front Steering Knuckle Assembly	110 ± 10
Coupling Nut Between Front Shock Absorber Assembly and Front Steering Knuckle Assembly	110 ± 10
Coupling Bolt Between Front Stabilizer Bar Assembly and Front Sub Frame Welding Assembly	20 ± 2
Coupling Bolt Between Front Sub Frame Welding Assembly and Steering Gear Assembly	100 ± 10
Coupling Bolt Between Upper Part of Front Sub Frame Welding Assembly and Body	180 ± 10
Coupling Bolt Between Rear Part of Front Sub Frame Welding Assembly and Body	180 ± 10
Coupling Bolt Between Rear Mounting Cushion Assembly Upper Body and Rear Mounting Cushion Assembly Lower Body	80 ± 5
Coupling Nut Between Rear Mounting Cushion Assembly Upper Body and Rear Mounting Cushion Assembly Lower Body	80 ± 5
Coupling Bolt Between Rear Mounting Cushion Assembly Lower Body and Front Sub Frame Welding Assembly	105 ± 5
Rear Shaft Assembly Locking Nut	240 ± 20
Coupling Bolt Between Rear Wheel Speed Sensor and Rear Steering Knuckle Assembly	10 ± 1
Coupling Bolt Between Rear Brake Line Fixing Bracket and Rear Steering Knuckle Assembly	18 ± 2
Coupling Bolt Between Parking Brake Cable Assembly Fixing Bracket and Rear Steering Knuckle Assembly	10 ± 1.5

22 - AXLE

Description	Torque (N·m)
Coupling Bolt Between Lower Part of Rear Shock Absorber Assembly and Rear Steering Knuckle Assembly	160 ± 10
Coupling Nut Between Rear Brake Plate Assembly Rear Hub Shaft and Rear Shaft Assembly	90 ± 5
Coupling Nut Between Rear Brake Plate Assembly Rear Hub Shaft and Rear Shaft Assembly	160 ± 10
Coupling Nut Between Rear Brake Plate Assembly Rear Hub Shaft and Rear Shaft Assembly	160 ± 10
Coupling Nut Between Rear Brake Plate Assembly Rear Hub Shaft and Rear Shaft Assembly	160 ± 10
Coupling Bolt Between Rear Shaft Welding Assembly and Body	135 ± 10

Clearance Specifications

Description	Specified Condition (mm)
Front Hub Bearing Looseness	0.032-0.057
Front Hub Bearing Runout	0.02
Rear Hub Bearing Looseness	0.035-0.055
Rear Hub Bearing Runout	0.05

Tools

Special Tool

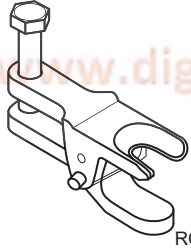
Ball Pin Separator	 <p>RCH0000024</p>
--------------------	---

General Tools

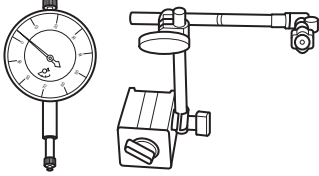
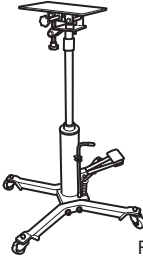
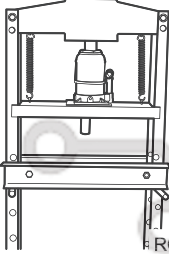
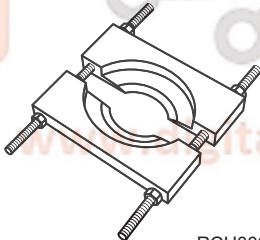
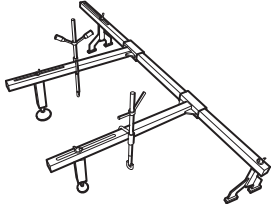
Dial Indicator and Magnetic Holder	 <p>RCH0000023</p>
Transmission Carrier	 <p>RCH0000005</p>
Hydraulic Press	 <p>RCH0000012</p>
Bearing Remover	 <p>RCH0000011</p>
Engine Equalizer	 <p>RCH0000026</p>

DIAGNOSIS & TESTING

Problem Symptoms Table

HINT:

Use symptoms table below to help determine cause of problem. Check each suspected area in sequence. Repair or adjust faulty components, or replace as necessary.

Symptom	Suspected Area	See page
Pulls	Tire (worn or improperly inflated)	24-3
	Front wheel alignment (incorrect)	23-33
	Rear wheel alignment (incorrect)	23-33
	Front hub bearing (loose or worn)	22-16
	Rear hub bearing (loose or worn)	22-21
	Steering gear (misaligned or damaged)	29-21
	Suspension component (worn)	23-9
Front wheel shimmy	Tire (worn or improperly inflated)	24-3
	Wheel (imbalanced)	24-10
	Front shock absorber assembly (stuck or damaged)	23-9
	Front wheel alignment (incorrect)	23-33
	Control arm assembly ball pin (stuck or damaged)	23-19
	Front hub bearing (loose or worn)	22-16
	Steering gear (misaligned or damaged)	29-21
Rear wheel shimmy	Tire (worn or improperly inflated)	24-3
	Wheel (imbalanced)	23-33
	Rear shock absorber assembly (stuck or damaged)	23-31
	Rear hub bearing (loose or worn)	22-21
	Rear wheel alignment (incorrect)	23-33

ON-VEHICLE SERVICE

Front Steering Knuckle

Removal

HINT:

Use same procedures for right and left sides.
Procedures listed below are for left side.

WARNING

- Be sure to wear necessary safety equipment to prevent accidents.
- Check if safety lock of lift is locked when repairing chassis parts.
- It is not permitted to weld or modify bearing parts of wheel suspension and guide parts of wheel.
- When removing chassis parts, replace self-locking nuts and rusted nuts for safety.

1. Remove the front left wheel (See page 24-7).
2. Remove the front drive shaft assembly locking nut.
 - a. Using a nut punch and a hammer, loosen staked part of nut.

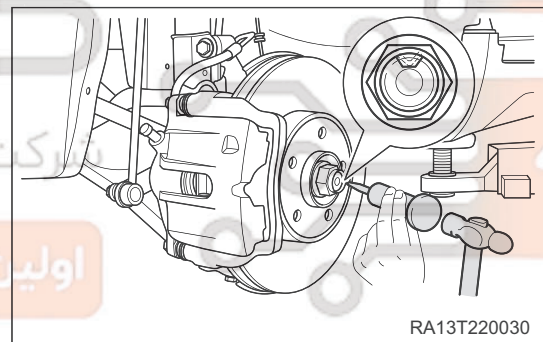

CAUTION

- Loosen staked part of nut completely, otherwise it will damage threads of drive shaft assembly.

- b. Remove front drive shaft assembly locking nut and washer (arrow) while applying brake securely.
(Tightening torque: 330 ± 20 N·m)

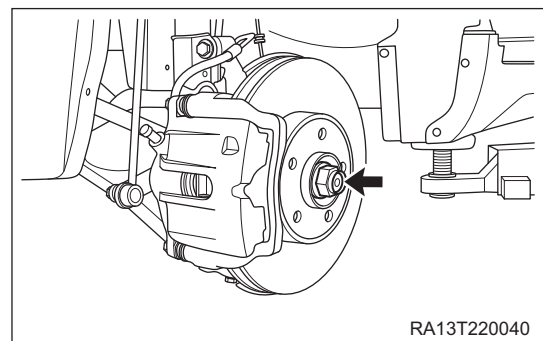

22 - AXLE

3. Remove the front left brake caliper assembly (See page 26-27).

 CAUTION

- Place front brake caliper assembly to a proper position after removal, and be careful not to extend front brake hose excessively.

4. Remove the front left brake disc (See page 26-28).

5. Remove the front left steering knuckle assembly.

- a. Remove coupling nut (arrow) between front left control arm assembly ball pin and front left steering knuckle assembly.

(Tightening torque: 100 ± 10 N·m)

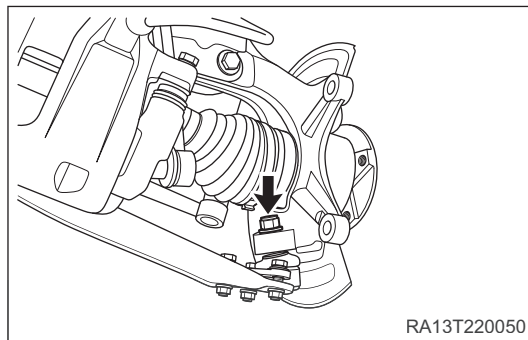

RA13T220050

- b. Remove 3 fixing bolts (arrow) between front left dust guard and front left steering knuckle assembly, and remove front left dust guard (1).

(Tightening torque: 9 - 11 N·m)

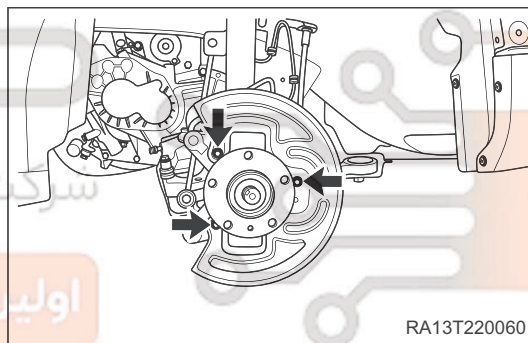

RA13T220060

- c. Remove coupling bolt (arrow) between front left wheel speed sensor and front left steering knuckle assembly, and disengage front left wheel speed sensor carefully.

(Tightening torque: 10 ± 1 N·m)

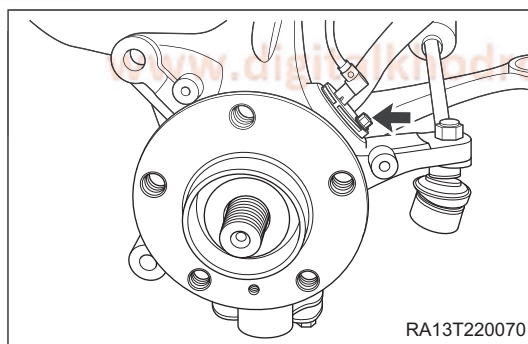

RA13T220070

- d. Remove self-locking nut (arrow) between left steering tie rod assembly ball pin and front left steering knuckle assembly.

(Tightening torque: 35 ± 3 N·m)

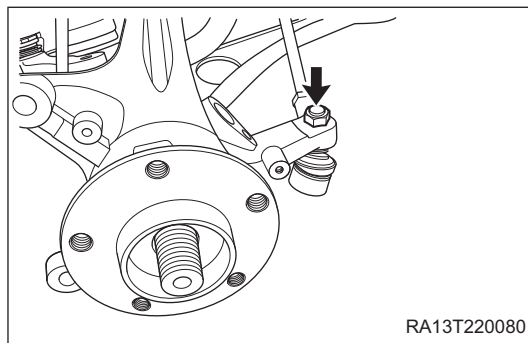

RA13T220080

- e. Install ball pin separator (1), and tighten ball pin separator bolt with a wrench (2) to separate steering tie rod ball pin from steering knuckle assembly.

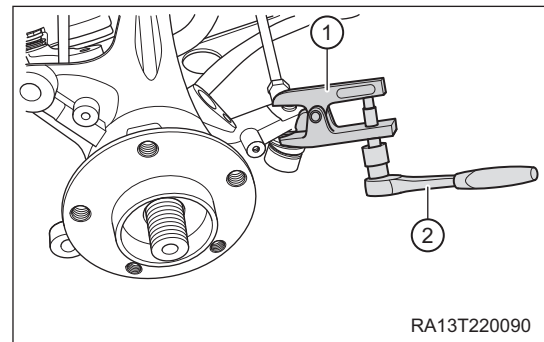

- f. Remove 2 coupling bolts and nuts (arrow) between front left shock absorber assembly and front left steering knuckle assembly.

(Tightening torque: 110 ± 10 N·m)

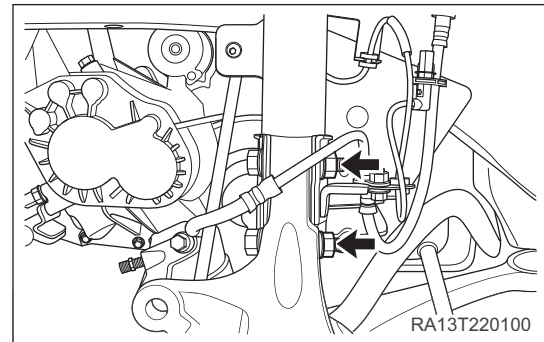

- g. Disengage left drive shaft and remove front left steering knuckle assembly.

Disassembly

1. Remove front steering knuckle assembly, front hub and front hub bearing.

- a. Remove front hub bearing retainer (arrow) with snap spring pliers.

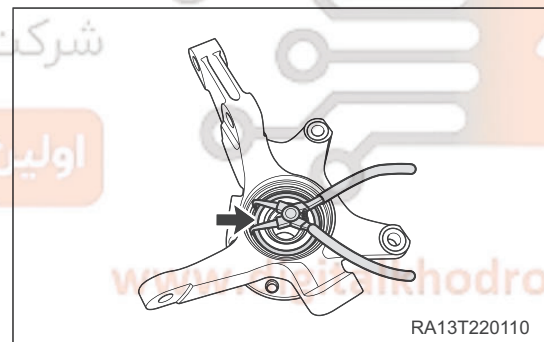

- b. Place front steering knuckle assembly on a hydraulic press, install bearing remover and adapter, and press out front hub with hydraulic press.

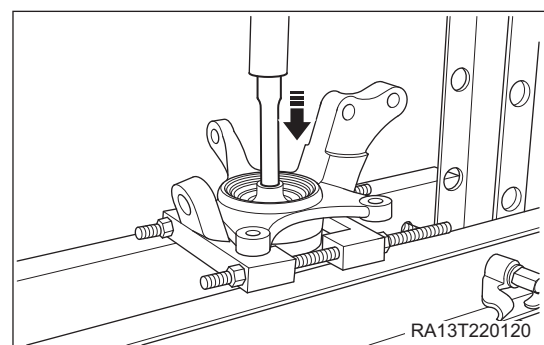

22 - AXLE

c. Remove the front hub carefully.

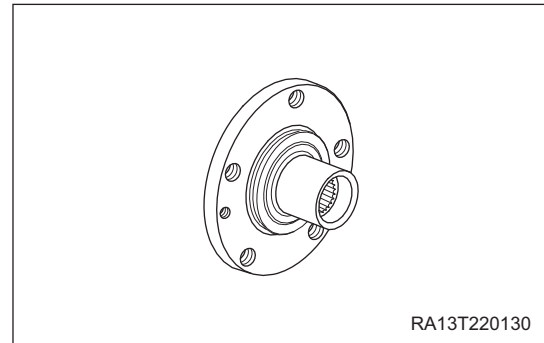

d. Place steering knuckle assembly on a hydraulic press, install bearing remover and adapter, and press out front hub bearing with hydraulic press.

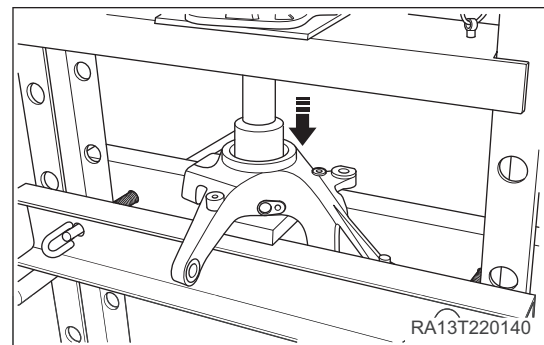

e. Remove the front hub bearing carefully.

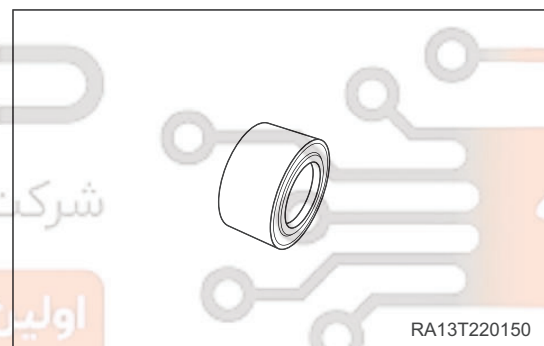

Inspection

1. Check the front steering knuckle and dust guard.
 - a. Check front steering knuckle for wear, cracks, deformation or damage. Replace as necessary.
 - b. Check dust guard for dirt, wear, cracks, deformation or damage. Replace as necessary.

Assembly

Assembly is in the reverse order of disassembly.

CAUTION

- Please note that opening of retainer must face opening of front wheel speed sensor, when installing front hub bearing retainer.

Installation

Installation is in the reverse order of removal.

CAUTION

- Be sure to tighten coupling bolts and nuts to specified torque.
- Check wheel alignment after installation is completed. Adjust wheel alignment to standard range as necessary.

دیجیتال خودرو

شرکت دیجیتال خودرو سامانه (مسئولیت محدود)

اولین سامانه دیجیتال تعمیرکاران خودرو در ایران



021 62 99 92 92

www.digitalkhodro.com

22 - AXLE

Front Hub Assembly

On-vehicle Inspection

1. Remove the front wheel (See page 24-7).
2. Remove the front brake caliper assembly (See page 26-27).
3. Remove the front brake disc (See page 26-28).
4. Check the front hub bearing looseness.
 - a. Check looseness near the center of front hub assembly with a dial indicator.
Maximum looseness: 0.032 - 0.057 mm

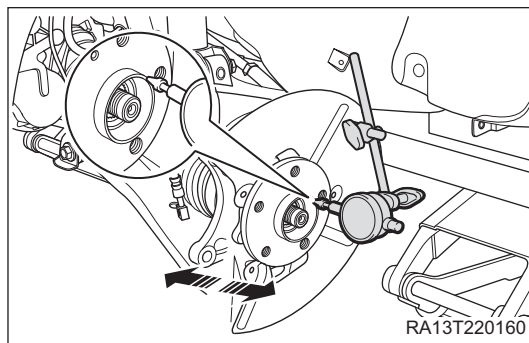

CAUTION

- Ensure that dial indicator is perpendicular to measurement surface.

If looseness exceeds maximum value, replace front hub bearing.

5. Check the front hub bearing runout.
 - a. Check runout of front hub assembly surface with a dial indicator.
Maximum runout: 0.02 mm

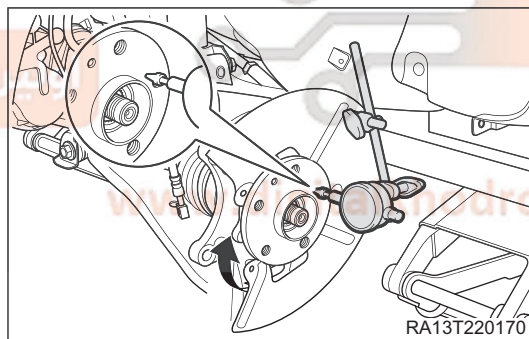

If runout exceeds maximum value, replace front hub bearing.

6. Install the front brake disc (See page 26-28).
7. Install the front brake caliper assembly (See page 26-28).
8. Install the front wheel (See page 24-7).

Removal

WARNING

- Be sure to wear necessary safety equipment to prevent accidents.
- Check if safety lock of lift is locked when repairing chassis parts.
- It is not permitted to weld or modify bearing parts of wheel suspension and guide parts of wheel.
- When removing chassis parts, replace self-locking nuts and rusted nuts for safety.

HINT:

Use same procedures for right and left sides.

Procedures listed below are for left side.

1. Remove the front left wheel (See page 24-7).
2. Remove the front drive shaft assembly locking nut (See page 22-9).
3. Remove the front left brake caliper assembly (See page 26-27).
4. Remove the front left brake disc (See page 26-28).
5. Remove the front left steering knuckle assembly (See page 22-10).
6. Remove the front hub assembly.
 - a. Remove front hub bearing retainer (arrow) with snap spring pliers.

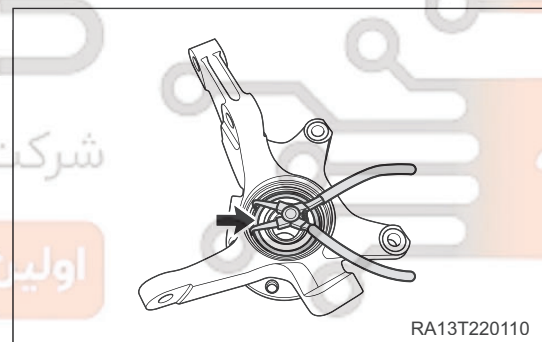

- b. Place front steering knuckle assembly on a hydraulic press, install bearing remover and adapter, and press out front hub with hydraulic press.

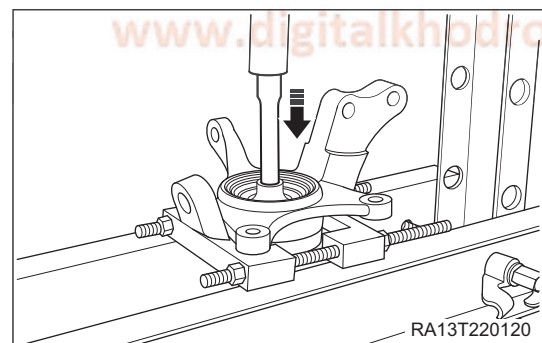

- c. Remove the front hub carefully.

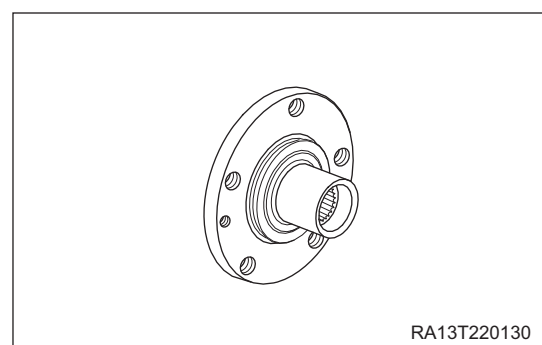

22 - AXLE

- d. Place steering knuckle assembly on a hydraulic press, install bearing remover and adapter, and press out front hub bearing with hydraulic press.

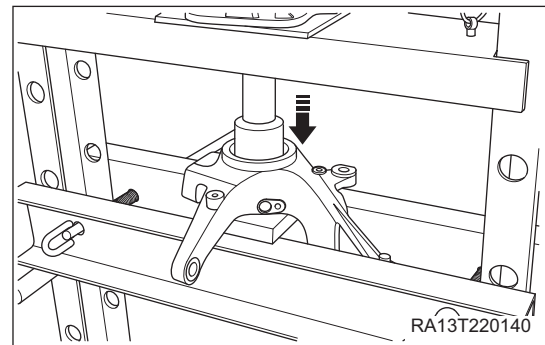

- e. Remove the front hub bearing carefully.

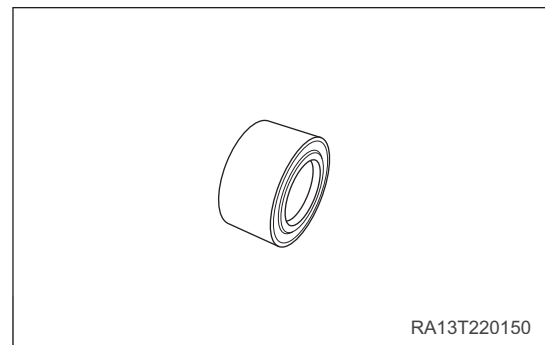

Installation

Installation is in the reverse order of removal.

CAUTION

- Please note that opening of retainer must face opening of front wheel speed sensor, when installing front hub bearing retainer.
- Be sure to tighten coupling bolts and nuts to specified torque.
- Check that hub assembly rotates smoothly and there is no seizing after installation.

Front Sub Frame Welding Assembly

Removal

WARNING

- Be sure to wear necessary safety equipment to prevent accidents.
- Check if safety lock of lift is locked when repairing chassis parts.
- It is not permitted to weld or modify bearing parts of wheel suspension and guide parts of wheel.
- When removing chassis parts, replace self-locking nuts and rusted nuts for safety.
- When removing front sub frame welding assembly, it is necessary to securely support engine and transmission assembly with engine equalizer to avoid damage.

1. Remove the front wheel (See page 24-7).
2. Remove the front sub frame welding assembly.
 - a. Using an engine equalizer, support engine and transmission assembly securely.
 - b. Disengage exhaust pipe fixing rubber lifting eyes (arrow) from front sub frame welding assembly.

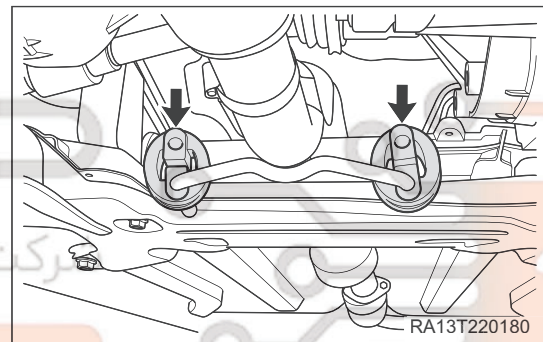

- c. Remove 4 fixing bolts (arrow) between power steering gear with tie rod assembly and sub frame. (Tightening torque: 30 ± 3 N·m)

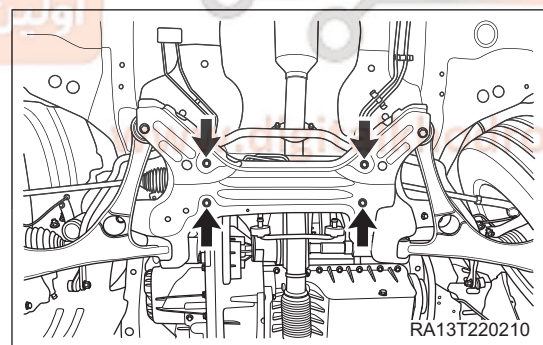

22 - AXLE

- d. Remove 2 fixing bolts (arrow) between engine right mounting cushion and sub frame.
(Tightening torque: 65 ± 5 N·m)

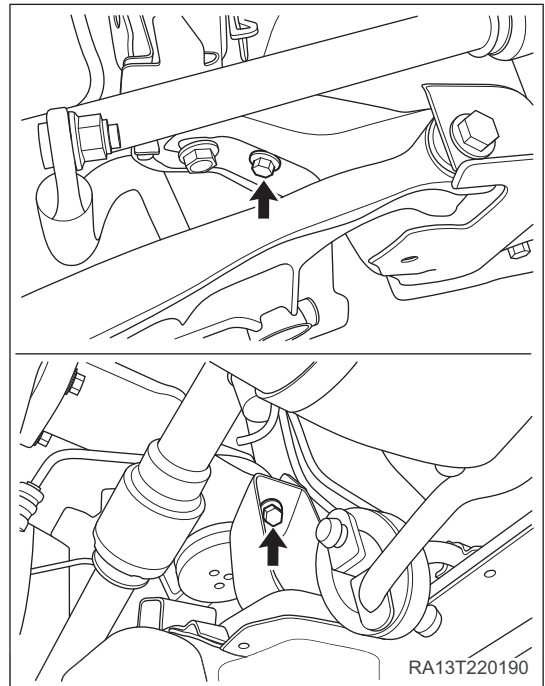

- e. Remove fixing bolt (arrow) between transmission left mounting cushion and left mounting bracket.
(Tightening torque: 65 ± 5 N·m)

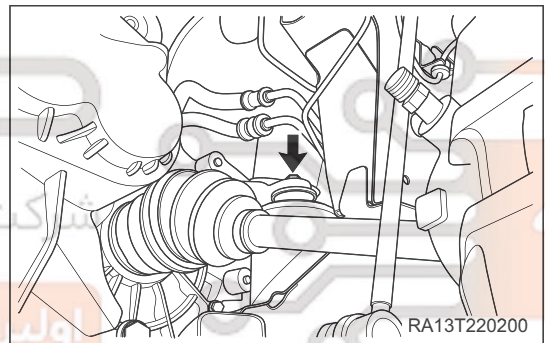

- f. Remove 4 fixing bolts (arrow) between sub frame and body.
(Tightening torque for front bolt: 135 ± 5 N·m)
(Tightening torque for rear bolt: 160 ± 16 N·m)

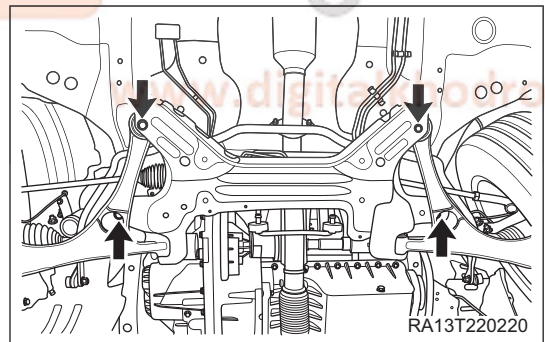

g. Remove 4 stabilizer bar fixing nuts from sub frame.

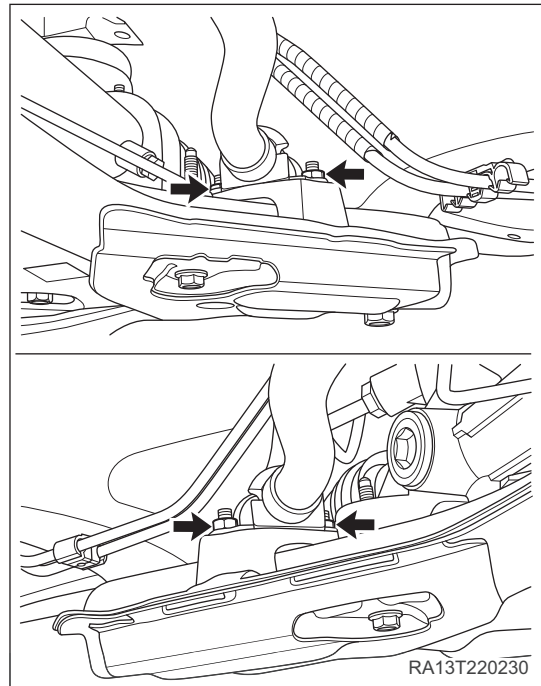

h. Using a transmission carrier, support front sub frame welding assembly.

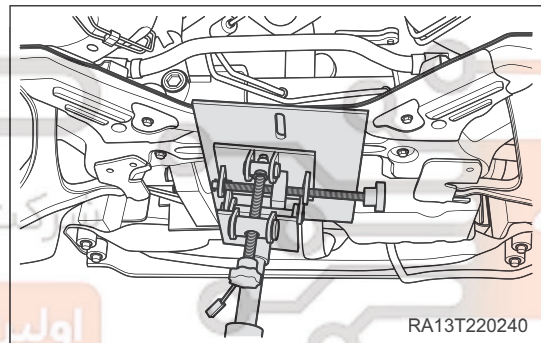

3. Remove the front control arm assembly (See page 23-17).

4. Remove the front sub frame welding assembly.

Installation

Installation is in the reverse order of removal.

CAUTION

- Be sure to tighten coupling bolts and nuts to specified torque.
- Check wheel alignment after installation is completed. Adjust wheel alignment to standard range as necessary.

Rear Hub Bearing Assembly

On-vehicle Inspection

1. Remove the rear wheel (See page 24-7).
2. Remove the rear brake caliper assembly (See page 26-38).
3. Remove the rear brake disc (See page 26-39).
4. Check the rear hub bearing looseness.
 - a. Check looseness near the center of rear hub bearing with a dial indicator.
Maximum looseness: 0.035 - 0.055 mm

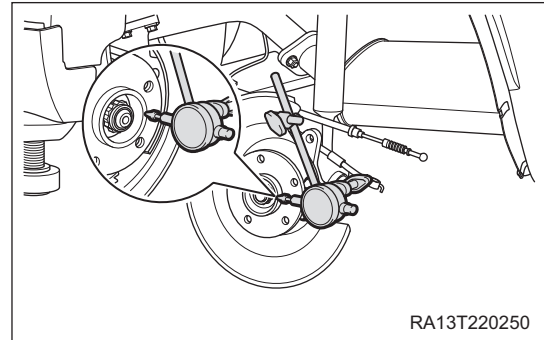

CAUTION

- Ensure that dial indicator is perpendicular to measurement surface.

If looseness exceeds maximum value, replace rear hub bearing assembly.

5. Check the rear hub bearing runout.
 - a. Check runout of rear hub bearing assembly surface with a dial indicator.
Maximum runout: 0.05 mm

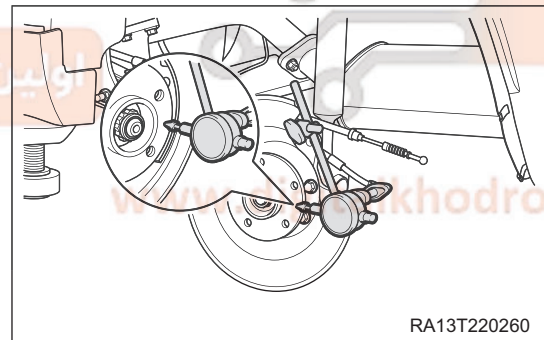

CAUTION

- Ensure that dial indicator is perpendicular to measurement surface.

If runout exceeds maximum value, replace rear hub bearing assembly.

6. Install the rear brake disc (See page 26-39).
7. Install the rear brake caliper assembly (See page 26-38).
8. Install the rear wheel (See page 24-7).

Removal

HINT:

Use same procedures for right and left sides.

Procedures listed below are for left side.

1. Remove the rear left wheel (See page 24-7).
2. Remove the rear left brake caliper assembly (See page 26-38).
3. Remove the rear left brake disc (See page 26-39).
4. Remove the rear left hub bearing assembly.
 - a. Using a flat tip screwdriver wrapped with protective tape, carefully pry out rear left bearing end cover (arrow).

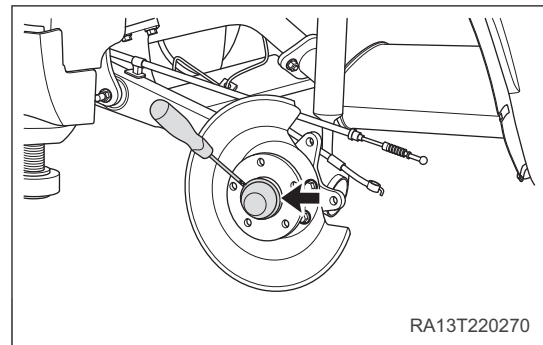

- b. Remove the rear shaft assembly left locking nut (arrow).
(Tightening torque: 240 ± 20 N·m)

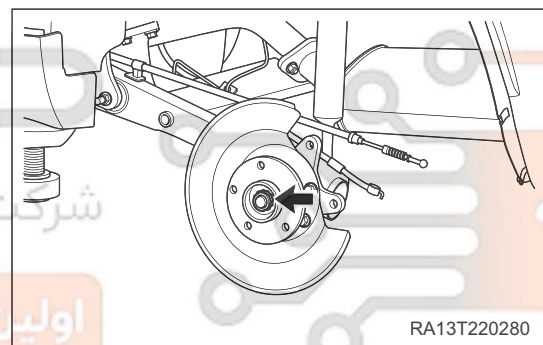

- c. Slightly wiggle rear left hub bearing assembly and pull it out.

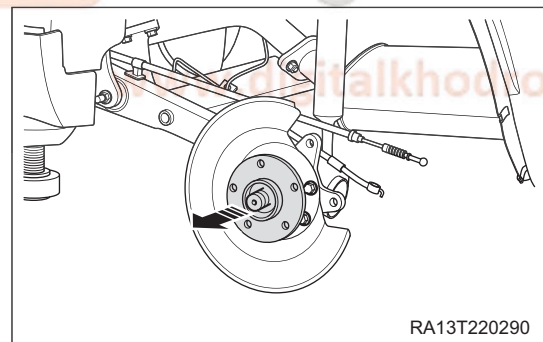

Installation

Installation is in the reverse order of removal.

CAUTION

- Be sure to tighten locking nut to specified torque.
- Make sure that rear hub assembly rotates smoothly and freely after installation.

Rear Hub Shaft

Removal

⚠ WARNING

- Be sure to wear necessary safety equipment to prevent accidents.
- Check if safety lock of lift is locked when repairing chassis parts.
- It is not permitted to weld or modify bearing parts of wheel suspension and guide parts of wheel.
- When removing chassis parts, replace self-locking nuts and rusted nuts for safety.

HINT:

Use same procedures for right and left sides.

Procedures listed below are for left side.

1. Remove the rear wheel (See page 24-7).
2. Remove coupling bolt (arrow) between rear wheel speed sensor and rear steering knuckle assembly, and disengage rear wheel speed sensor.

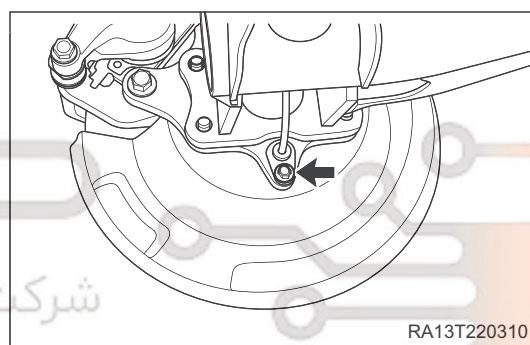

3. Remove the rear brake caliper assembly (See page 26-27).

4. Remove the rear brake disc (See page 26-39).

5. Remove the rear hub bearing assembly (See page 26-39).

6. Remove the rear hub assembly.

- a. Remove 4 fixing bolts (arrow) between rear hub shaft and brake plate assembly.

(Tightening torque: 60 ± 5 N·m)

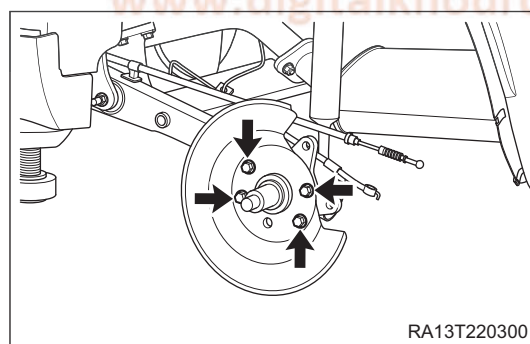

- b. Remove wallboard and rear hub shaft.

Installation

Installation is in the reverse order of removal.

CAUTION

- Be sure to tighten coupling bolts and nuts to specified torque.
- Check and adjust wheel alignment after installation is completed. Adjust wheel alignment to standard range as necessary.

دیجیتال خودرو

شرکت دیجیتال خودرو سامانه (مسئولیت محدود)

اولین سامانه دیجیتال تعمیرکاران خودرو در ایران



021 62 99 92 92

www.digitalkhodro.com

Rear Shaft Assembly

Removal

⚠ WARNING

- Be sure to wear necessary safety equipment to prevent accidents.
- Check if safety lock of lift is locked when repairing chassis parts.
- It is not permitted to weld or modify bearing parts of wheel suspension and guide parts of wheel.
- When removing chassis parts, replace self-locking nuts and rusted nuts for safety.

1. Remove the rear wheel. (See page 24-7).
2. Drain the brake fluid . (See page 26-15).
3. Remove the wheel speed sensor (See page 22-22).
4. Remove the parking brake cable. (See page 27-13).
5. Remove the rear brake disc. (See page 26-39).
6. Remove the rear hub shaft assembly. (See page 22-22).
7. Remove the rear shaft assembly.
 - a. Remove coupling bolt and nut (arrow) between rear left shock absorber assembly and rear shaft assembly. Use same removal procedure for right side. (Tightening torque: $110 \pm 10 \text{ N}\cdot\text{m}$)

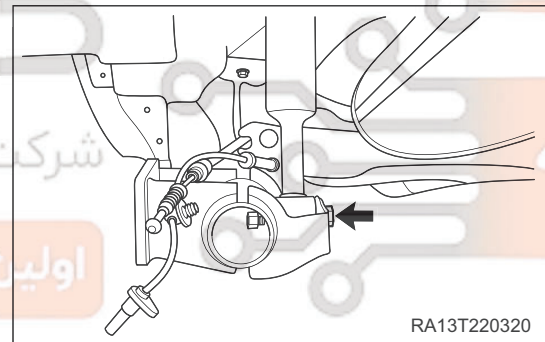

- b. Remove 2 coupling bolts (arrow) between rear brake pipe and rear brake hose, and remove rear brake pipe and rear brake hose.

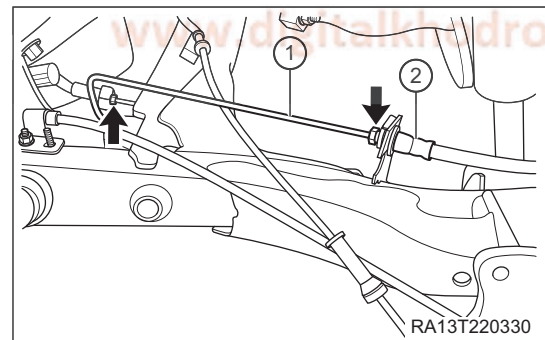

- c. Install transmission carrier to support rear shaft.

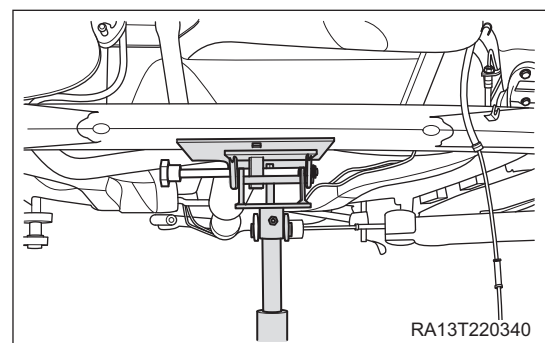

- d. Remove coupling bolt (arrow) between left of rear shaft assembly and body. Use same removal procedure for right side.
(Tightening torque: 120 ± 10 N·m)

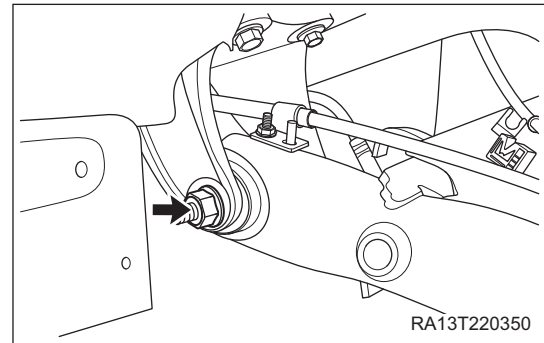

- e. Remove the rear shaft assembly.

Installation

Installation is in the reverse order of removal.

CAUTION

- Be sure to tighten coupling bolts and nuts to specified torque.
- Bounce vehicle up and down several times to stabilize rear suspension after installation.

دیجیتال خودرو

شرکت دیجیتال خودرو سامانه (مسئولیت محدود)

اولین سامانه دیجیتال تعمیرکاران خودرو در ایران



021 62 99 92 92

www.digitalkhodro.com

- MEMO -

دیجیتال خودرو

شرکت دیجیتال خودرو سامانه (مسئولیت محدود)

اولین سامانه دیجیتال تعمیرکاران خودرو در ایران



021 62 99 92 92

www.digitalkhodro.com