

RESTRAINTS

14

CONTENTS

	page
Airbag System	14-1
Seat Belt System	14-50

AIRBAG SYSTEM

GENERAL INFORMATION	14-2	B1352 - Passenger Airbag Resistance	
Description	14-2	Too High Or Open (1st Stage)	14-23
Operation	14-2	B2501 - Warning Lamp Fault-Open	14-29
Specifications	14-2	B2503 - Warning Lamp Fault-Short To	
Special Tools	14-3	Ground	14-33
Electrical Schematics	14-4	B2504 - Warning Lamp Fault-Short To	
Airbag Control Module Connector Pin-Out		Battery	14-37
Table	14-7	B1620 - Internal Fault - Replace ECU	14-41
DIAGNOSIS & TESTING	14-8	ON-VEHICLE SERVICE	14-46
Diagnostic Help	14-8	Airbag System Disarming Procedure	14-46
Intermittent DTC Troubleshooting	14-8	Description	14-46
Ground Inspection	14-8	Driver Side Airbag	14-46
Diagnostic Tools	14-8	Removal & Installation	14-46
Diagnostic Trouble Code (DTC) List	14-9	Front Passenger Side Airbag	14-47
Restraints Control Module DTC List	14-9	Removal & Installation	14-47
Diagnostic Trouble Code (DTC) Tests	14-11	Restraints Control Module (RCM)	14-49
B1102 - Battery Voltage Low	14-11	Removal & Installation	14-49
B1346 - Driver Airbag Resistance Too			
High Or Open (1st Stage)	14-16		

GENERAL INFORMATION

Description

Available occupant restraints for this vehicle include both active and passive types. Active restraints are those which require the vehicle occupants to take some action to employ, such as fastening a seat belt; while passive restraints require no action by the vehicle occupants to be employed.

Active Restraints

- Front Seat Belts
- Rear Seat Belts

Passive Restraints

- Driver Airbag
- Passenger Airbag
- Seat Belt Tensioners

Operation

Active Restraints

The primary passenger restraints are the seat belts. Seat belts are referred to as an active restraint because the vehicle occupants are required to physically fasten and properly adjust these restraints in order to benefit from them.

Passive Restraints

The passive restraints are referred to as a supplemental restraint system because they were designed and are intended to enhance the protection for the occupants of the vehicle only when used in conjunction with the seat belts. They are referred to as passive restraints because the vehicle occupants are not required to do anything to make them operate; however, the vehicle occupants must be wearing their seat belts in order to obtain the maximum safety benefit from the supplemental restraint system.

The supplemental restraint system electrical circuits are continuously monitored and controlled by a microprocessor and software contained within the Restraints Control Module (RCM). An airbag indicator in the instrument cluster illuminates for about seven seconds as a bulb test each time the ignition switch is turned to the ON or START positions. Following the bulb test, the airbag indicator is turned ON or OFF by the RCM to indicate the status of the supplemental restraint system. If the airbag indicator comes ON at any time other than during the bulb test, it indicates that there is a problem in the supplemental restraint system electrical circuits. Such a problem may cause airbags not to deploy when required, or to deploy when not required.

Deployment of the supplemental restraints depends upon the angle and severity of an impact. When an impact is severe enough, the microprocessor in the RCM signals the inflator of the appropriate airbag units to deploy their airbag cushions. The front seat belt tensioners are provided with a deployment signal by the RCM in conjunction with the front airbags.

Specifications

Torque Specifications

DESCRIPTION	TORQUE (N·m)
Driver Side Airbag Retaining Bolts	10
Restraints Control Module Retaining Bolts	7-9
Front Passenger Side Airbag Retaining Bolts	10

GENERAL INFORMATION

Special Tools

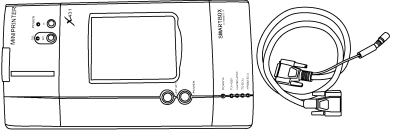
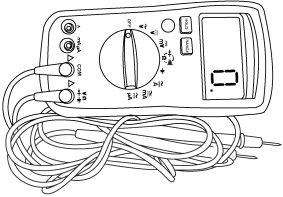
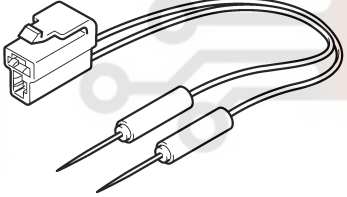
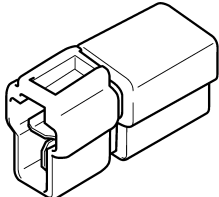
<p>Diagnostic Scan Tool X-431</p>	 <p>besm030001</p>
<p>Digital Multimeter Fluke 15B & 17B</p>	 <p>besm030002</p>
<p>General Airbag Special Load Tool - Resistor Harness (For Driver's and Passenger's (Front) Airbag)</p>	 <p>Itsmd140011</p>
<p>General Airbag Special Load Tool - Dummy Resistor</p>	 <p>Itsmd140010</p>

GENERAL INFORMATION

Electrical Schematics

Airbag Control System (Page 1 of 3)

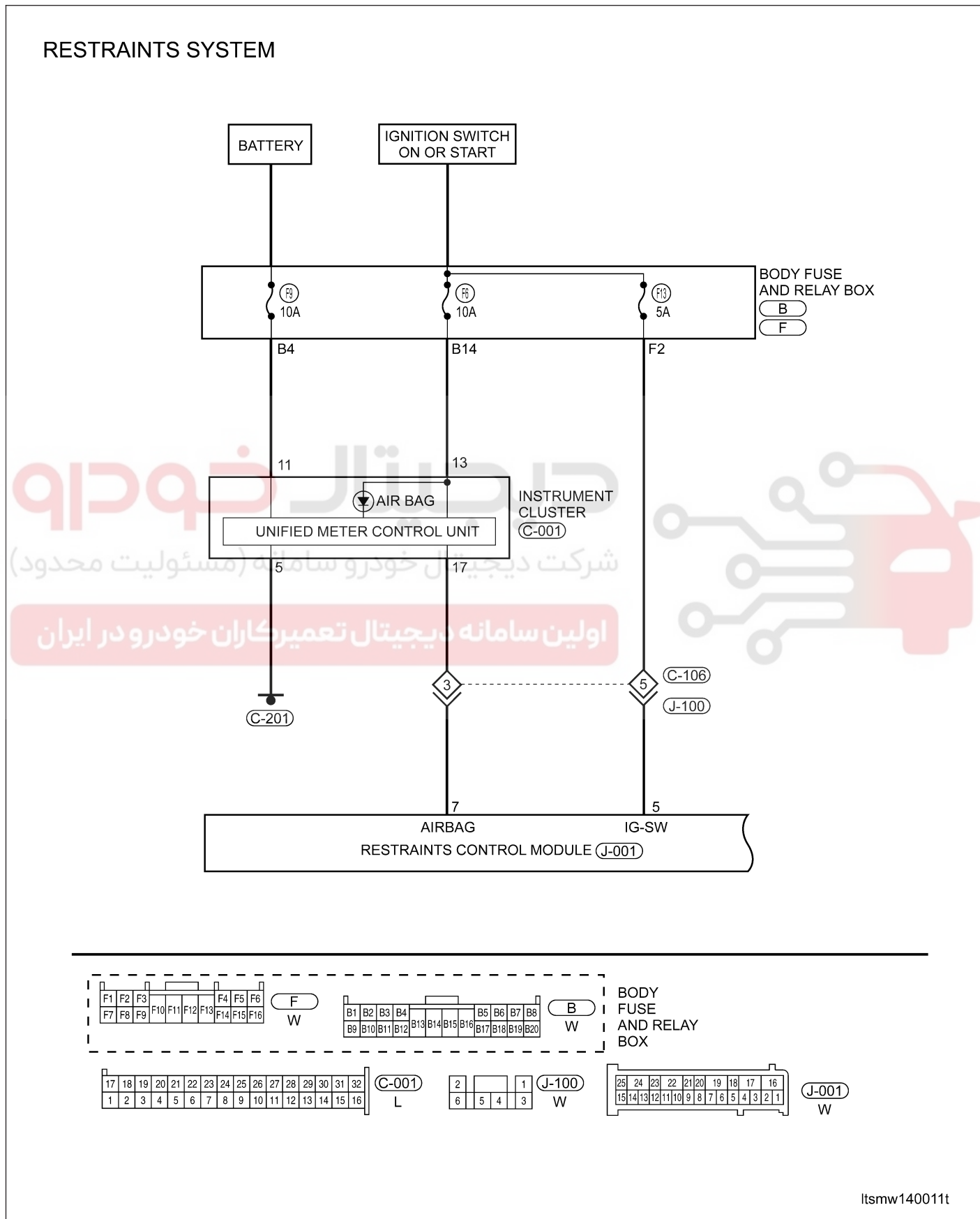

GENERAL INFORMATION

Airbag Control System (Page 2 of 3)

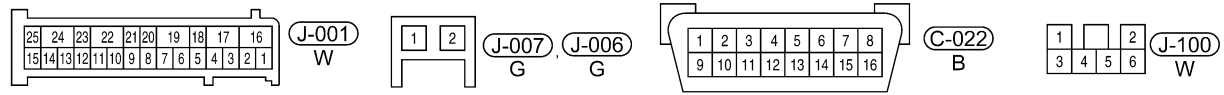
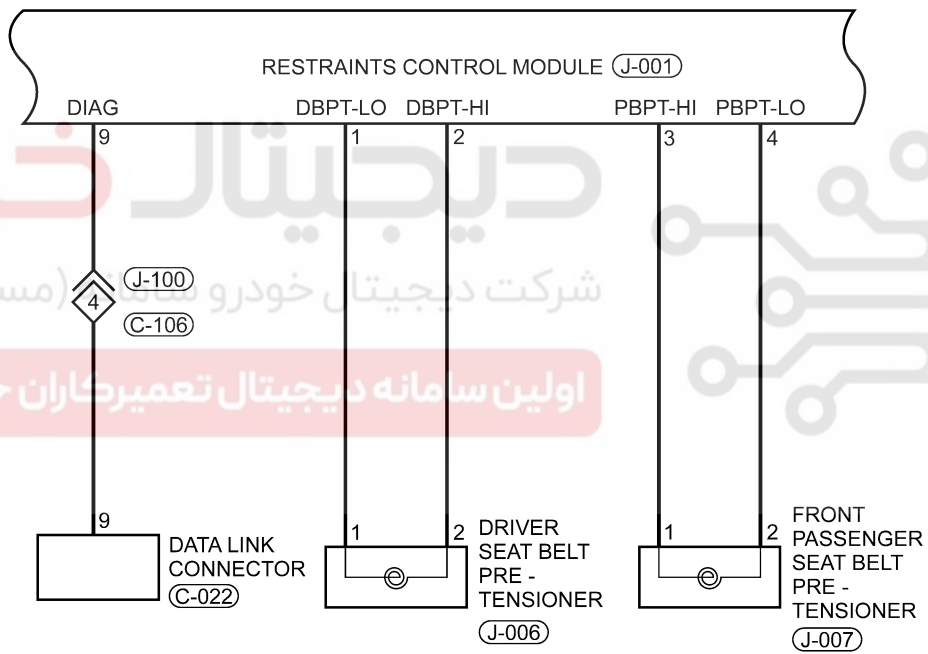

ltsmw140009t

GENERAL INFORMATION

Airbag Control System (Page 3 of 3)

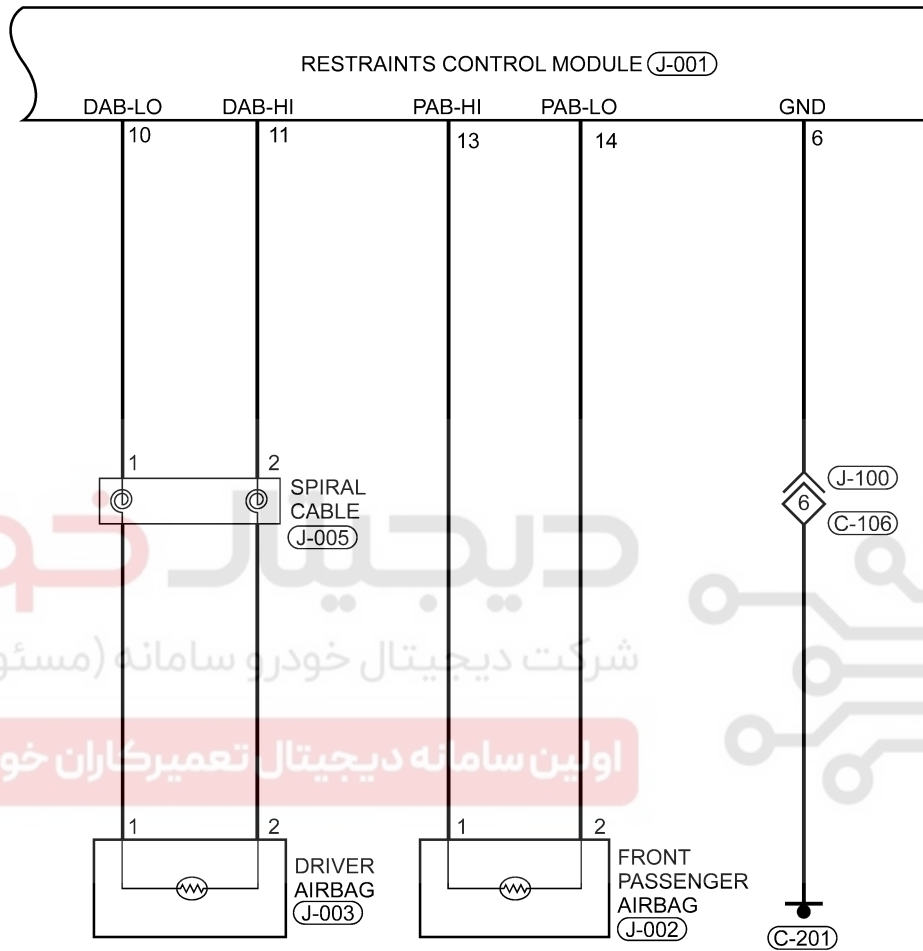

دیجیتال خودرو
شرکت دیجیتال خودرو سامانه (مسئولیت محدود)
اولین سامانه دیجیتال تعمیرکاران خودرو در ایران

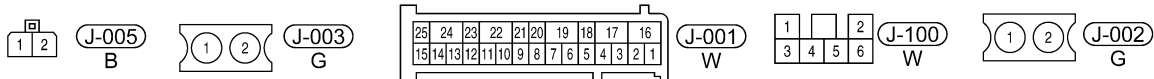
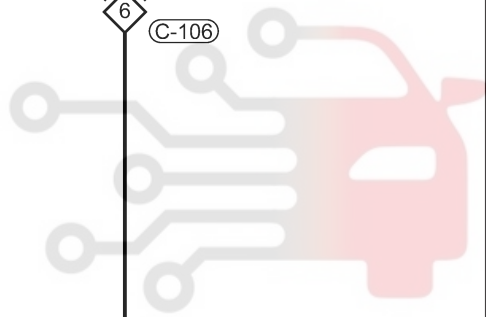

GENERAL INFORMATION

Airbag Control Module Connector Pin-Out Table

PIN	CIRCUIT IDENTIFICATION	PIN	CIRCUIT IDENTIFICATION
1	Driver Seatbelt Pre-tensioner Lo	14	Front Passenger Airbag Lo
2	Driver Seatbelt Pre-tensioner Hi	15	-
3	Front Passenger Seatbelt Pre-tensioner Hi	16	-
4	Front Passenger Seatbelt Pre-tensioner Lo	17	-
5	Ignition Switch	18	-
6	GND	19	-
7	Airbag Lamp	20	-
8	-	21	-
9	Diagnostic Link K	22	-
10	Driver Airbag Lo	23	-
11	Driver Airbag Hi	24	-
12	-	25	-
13	Front Passenger Airbag Hi		

دیجیتال خودرو

شرکت دیجیتال خودرو سامانه (مسئولیت محدود)

اولین سامانه دیجیتال تعمیرکاران خودرو در ایران



DIAGNOSIS & TESTING

Diagnostic Help

1. The X-431 scan tool connects to the Data Link Connector (DLC) and communicates with the vehicle electronic modules through the data network.
2. Confirm that the malfunction is current and carry-out the diagnostic tests and repair procedures.
3. If the DTC cannot be deleted, it is a current fault.
4. Use a digital multimeter to perform voltage readings on electronic systems.
5. Refer to any Technical Bulletins that may apply to the failure.
6. Visually inspect the related wiring harness.
7. Inspect and clean all Restraints Control Module (RCM) grounds that are related to DTC.
8. If numerous trouble codes were set, use a wiring schematic and look for any common ground circuits or voltage supply circuits that may apply to the DTC.

Intermittent DTC Troubleshooting

If the failure is intermittent perform the following:

- Check for loose connectors.
- Look for any chafed, pierced, pinched, or partially broken wires.
- Monitor the scan tool data relative to this circuit.
- Wiggle the related wiring harness and connectors while looking for an interrupted signal on the affected circuit.
- If possible, try to duplicate the conditions under which the DTC set.
- Look for the data to change or for the DTC to reset during the wiggle test.
- Look for broken, bent, pushed out or corroded terminals.
- Inspect the sensor and mounting area for any condition that would result in an incorrect signal, such as damage, foreign material.
- A data recorder, and/or oscilloscope should be used to help diagnose intermittent conditions.
- Remove the Restraints Control Module (RCM) from the troubled vehicle and install in a new vehicle and test. If the DTC cannot be deleted, the RCM is malfunctioning. If the DTC can be deleted, return the RCM to the original vehicle.

Ground Inspection

Ground connections are very important to the proper operation of electrical and electronic circuits. Ground connections are often exposed to moisture, dirt and other corrosive elements. The corrosion (rust) can become an unwanted resistance. This added resistance can alter the way a circuit works.

Electronically controlled circuits are very sensitive to proper grounding. A loose or corroded ground can drastically affect an electronically controlled circuit. A poor or corroded ground can affect the circuit. Perform the following when inspecting a ground connection:

1. Remove the ground bolt or screw.
2. Inspect all mating surface for tarnish, dirt, rust, etc.
3. Clean as required to assure good contact.
4. Reinstall bolt or screw securely.
5. Inspect for "add-on" accessories which may be interfering with the ground circuit.
6. If several wires are crimped into one ground eyelet terminal, check for proper crimps. Make sure all of the wires are clean, securely fastened and providing a good ground path. If multiple wires are crimped to one eyelet, make sure no excess wire insulation has been crimped creating a bad ground.

Diagnostic Tools

Diagnostic Scan Tool X-431

Read the following when connecting the X-431 scan tool:

- Connect the scan tool to the Data Link Connector (DLC) for communication with the vehicle.
- The DLC is located on the driver side compartment under the steering column (it is attached to the instrument panel and accessible from the driver seat).
- The DLC is rectangular in design and capable of accommodating up to 16 terminals.
- The electrical connector has keying features to allow easy connection.

DIAGNOSIS & TESTING

Airbag Special Load Tool

Use the airbag special load tools to diagnose airbag system faults:

- The airbag special load tools simulates airbag system components.

NOTE :

Using the airbag special load tools will help prevent other airbag DTCs from being set while troubleshooting the system.

Digital Multimeter

Read the following when using the digital multimeter:

- Troubleshoot electrical problems and wiring systems.
- Use a multimeter for basic fault finding and bench testing.
- Use a multimeter to measure voltage, current and resistance.

Diagnostic Trouble Code (DTC) List

Restraints Control Module DTC List

DTC	DTC DEFINITION
B1101	Battery Voltage High
B1102	Battery Voltage Low
B1345	Driver Airbag Open
B1346	Driver Airbag Resistance Too High (1st Stage)
B1347	Driver Airbag Resistance Too Low (1st Stage)
B1348	Driver Airbag Resistance Circuit Short To Ground (1st Stage)
B1349	Driver Airbag Resistance Circuit Short To Battery (1st Stage)
B1351	Passenger Airbag Open
B1352	Passenger Airbag Resistance Too High (1st Stage)
B1353	Passenger Airbag Resistance Too Low (1st Stage)
B1354	Passenger Airbag Resistance Circuit Short To Ground (1st Stage)
B1355	Passenger Airbag Resistance Circuit Short To Battery (1st Stage)
B1360	Pretensioner Front-Driver Open
B1361	Pretensioner Front-Driver Resistance Too High
B1362	Pretensioner Front-Driver Resistance Too Low
B1363	Pretensioner Front-Driver Resistance Circuit Short To Ground
B1364	Pretensioner Front-Driver Resistance Circuit Short To Battery
B1366	Pretensioner Front-Passenger Open
B1367	Pretensioner Front-Passenger Resistance Too High
B1368	Pretensioner Front-Passenger Resistance Too Low
B1369	Pretensioner Front-Passenger Resistance Circuit Short To Ground
B1370	Pretensioner Front-Passenger Resistance Circuit Short To Battery
B1406	PPD Front-Passenger Defect
B1407	PPD Front-Passenger Communication Error
B1462	Front PPD Open
B1511	Buckle Switch Driver Open Or Short To Battery
B1512	Buckle Switch Driver Short Or Short To Ground
B1513	Buckle Switch Passenger Open Or Short To Battery
B1514	Buckle Switch Passenger Short Or Short To Ground

DIAGNOSIS & TESTING

DTC	DTC DEFINITION
B1515	Buckle Switch Driver Defect
B1516	Buckle Switch Passenger Defect
B1527	Passenger Airbag Deactivation Switch Open Or Short To Battery
B1528	Passenger Airbag Deactivation Switch Short Or Short To Ground
B1529	Passenger Airbag Deactivation Switch Defect
B1650	Crash Record In 1st Stage Only (Frontal - Replace ECU)
B1657	Crash Record In Belt Pretensioner Only
B1658	Belt Pretensioner 6 Times Deployment
B1620	Internal Fault - Replace ECU
B2501	Warning Lamp Fault - Open
B2503	Warning Lamp Fault - Short To Ground
B2504	Warning Lamp Fault - Short To Battery
B2505	Passenger Airbag Off Warning Lamp Failure

دیجیتال خودرو

شرکت دیجیتال خودرو سامانه (مسئولیت محدود)

اولین سامانه دیجیتال تعمیرکاران خودرو در ایران



DIAGNOSIS & TESTING

Diagnostic Trouble Code (DTC) Tests

B1102 - Battery Voltage Low

SRC - PWR - 01

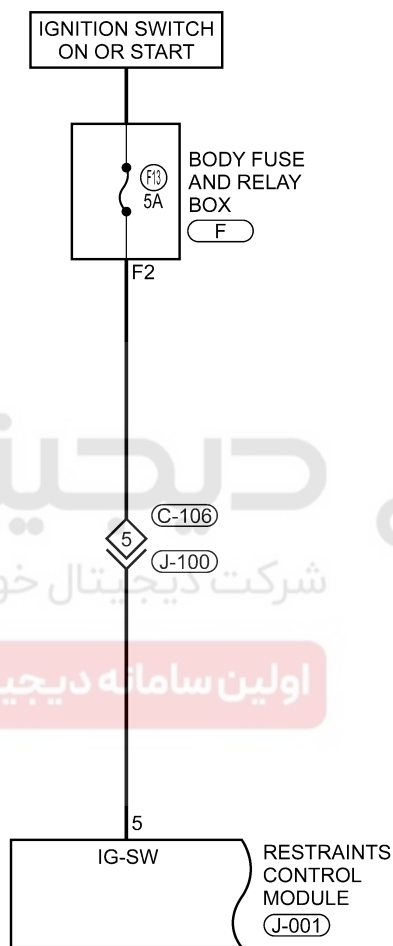

دیجیتال خودرو
 شرکت دیجیتال خودرو سامانه (مسئولیت محدود)
 اولین سامانه دیجیتال تعمیرکاران خودرو در ایران

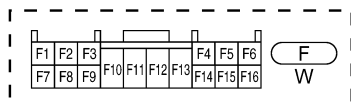

BODY FUSE AND RELAY BOX



J-100

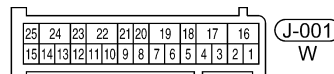

J-001

ltsmw140002t

DIAGNOSIS & TESTING

SRC - PWR - 02

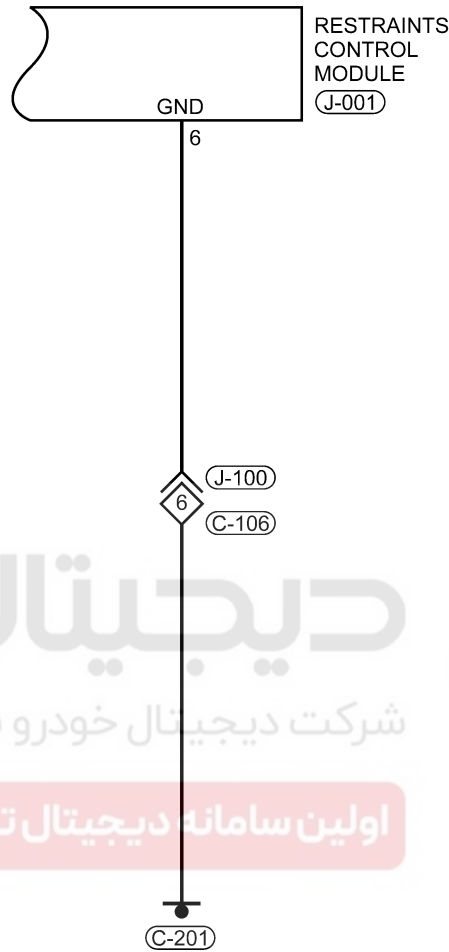

دیجیتال خودرو
 شرکت دیجیتال خودرو سامانه (مسئولیت محدود)
 اولین سامانه دیجیتال تعمیرکاران خودرو در ایران

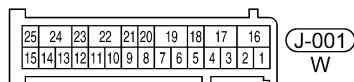
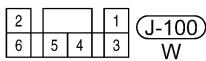

Itsmw140003t

DIAGNOSIS & TESTING

NOTE :

The Restraints Control Module (RCM) ground pin must be connected to the vehicle chassis in the immediate location of the RCM mounting area.

On Board Diagnostic Logic

- Self-diagnosis detection logic.

DTC NO.	DTC DEFINITION	DTC DETECTION CONDITION	DTC SET CONDITION	POSSIBLE CAUSE
B1102	Battery Voltage Low	Ignition switch: ON	Restraints Control Module (RCM) detected that the battery voltage is excessively low.	<ul style="list-style-type: none"> • Battery • Charge system • Harness is open or shorted • RCM

DTC Confirmation Procedure:

Before performing the following procedure, confirm that battery voltage is more than 12 V.

- Turn ignition switch off.
- Connect the X-431 scan tool to the Data Link Connector (DLC) - use the latest software available.
- Turn ignition switch on.
- With the scan tool, record and erase stored DTCs in the RCM.
- Turn ignition switch off and wait for a few seconds.
- Turn ignition switch on then select view DTC.
- If the DTC is detected, the DTC condition is current. Go to Diagnostic Procedure - Step 1.
- If the DTC is not detected, the DTC condition is intermittent (See Diagnostic Help and Intermittent DTC Troubleshooting in Section 14 Restraints for more information).

Diagnostic Guide Lines

Observe the following guide lines while diagnosing this DTC:

- Troubleshoot any Engine Control Module (ECM) charging/cranking DTCs before proceeding.
- If the warning lamp goes out immediately after the warning lamp flashed for 6 - 7 seconds, this indicates that the system is OK.
- If the warning lamp is on for 6 - 7 seconds continuously, then goes out, or the warning lamp is on continuously, this indicates that there are history DTCs in the system. Use the Scan Tool to erase the DTCs.
- If any other condition occurs, use the Scan Tool to erase the history DTCs first, then check the warning lamp. If the warning lamp does not go out immediately after the warning lamp flashes for 6 - 7 seconds when using the Scan Tool, erase the history DTCs first.
- In the course of troubleshooting the airbag system, make sure the system power supply is shut off, and wait two minutes for the system capacitor to discharge.
- The squib circuit connectors integrate a "shorting" spring (which prevents the airbag from deploying unintentionally due to static electricity by shorting the positive wire to the negative wire in the squib circuit when the connectors are disconnected). Therefore, if the airbag electrical connector or spiral cable electrical connector is damaged or improperly connected, the shorting spring may not be released when the electrical connector is connected.
- The following tools are required to perform the DTC diagnostic procedure:
 - X-431 Scan Tool
 - Airbag Special Load Tool
 - Digital Multimeter

NOTE :

While performing electrical diagnosis & testing, always refer to the electrical schematics for specific circuit and component information.

DIAGNOSIS & TESTING

Diagnostic Procedure

1. CHECK GROUND CONNECTION

- Turn ignition switch off.
- Disconnect the negative battery cable.
- Loosen and retighten ground screws on the body (See Ground Inspection in Section 14 Restraints for more information).
- Inspect the ground connection C-201 mounting position (See Vehicle Wiring Harness Layout - Main Harness in Section 16 Wiring).

Is the ground connection OK?

Yes >> Go to the next step.

No >> Repair or replace ground connection.

2. CHECK RESTRAINTS CONTROL MODULE (RCM) ELECTRICAL CONNECTOR

- Disconnect the Restraints Control Module (RCM) electrical connector (1).
- Inspect the electrical connector for damage.

Is the electrical connector OK?

Yes >> Go to the next step.

No >> Repair or replace the electrical connector as necessary.

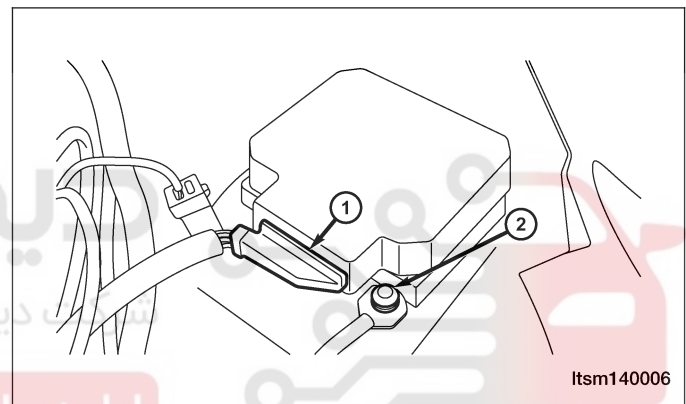

3. CHECK RESTRAINTS CONTROL MODULE (RCM) POWER SUPPLY

- Turn ignition switch on.
- Check RCM power supply between terminal 5 and terminal 6 in the RCM electrical connector J-001 terminal side.

Is the voltage less than 9 V?

Yes >> Go to step 4.

No >> Replace the RCM.

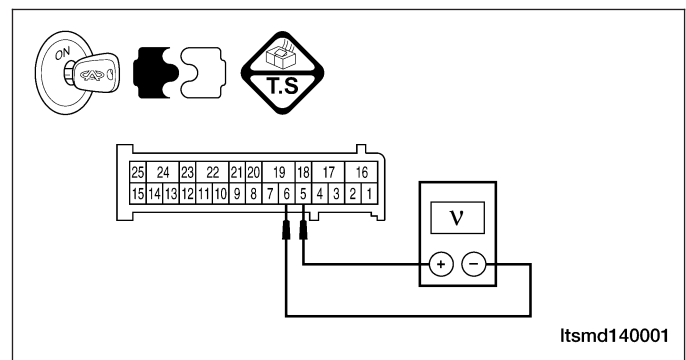

DIAGNOSIS & TESTING

4. CHECK SYSTEM VOLTAGE

- Start the engine, raise the engine speed over 1000 RPM.
- Measure the charging voltage with a voltmeter at the battery positive and negative terminals.

Is the voltage less than 9 V?

Yes >> Inspect the charging system.

No >> Go to the next step.

5. CHECK THE BATTERY

- Start the engine, raise the engine speed over 1000 RPM for a few minutes.
- Turn ignition switch off.
- Measure the voltage drop with a voltmeter at the battery positive and negative terminals while cranking the engine.
- Battery voltage should be more than approximate 9.0 V.

Is the check result normal?

Yes >> Go to step 6.

No >> Charge or replace the battery.

6. CHECK RESTRAINTS CONTROL MODULE (RCM) SUPPLY CIRCUIT

- Measure the resistance between RCM terminal 5 and the battery negative connector.
- Continuity should exist.

Is the check result normal?

Yes >> Go to the next step.

No >> Check fuse.
Inspect and replace the harness for an open.
Check harness connector C-106, J-100.
Check correlative components.

7. CHECK DTC

- With the X-431 scan tool, read RCM DTCs.
- Refer to "DTC Confirmation Procedure".

Is DTC B1102 still present?

Yes >> Replace the RCM.

No >> The system is now operating properly.
Reassemble the vehicle and road test to verify the customers complaint is repaired.

DIAGNOSIS & TESTING

B1346 - Driver Airbag Resistance Too High Or Open (1st Stage)

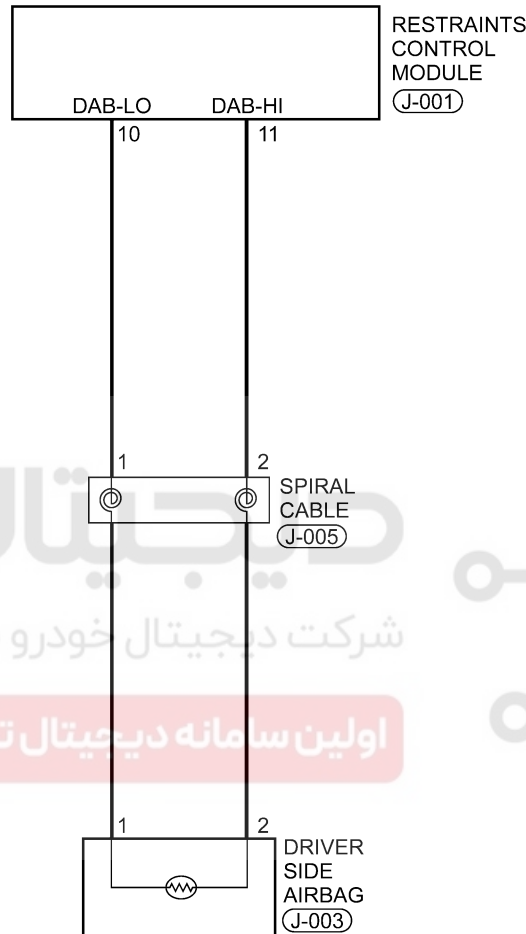

دیجیتال خودرو
شرکت دیجیتال خودرو سامانه (مسئولیت محدود)
اولین سامانه دیجیتال تعمیرکاران خودرو در ایران

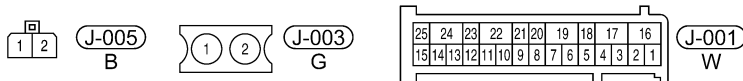

DIAGNOSIS & TESTING

NOTE :

The Restraints Control Module (RCM) ground pin must be connected to the vehicle chassis in the immediate location of the RCM mounting area.

WARNING!

After installing the Restraints Control Module (RCM), make sure all of the connectors are firmly connected, and the harness is routed properly. The resistance between the RCM housing and the vehicle body should be less than 100 mΩ.

On Board Diagnostic Logic

- Self-diagnosis detection logic.

DTC NO.	DTC DEFINITION	DTC DETECTION CONDITION	DTC SET CONDITION	POSSIBLE CAUSE
B1346	Driver Airbag Resistance Too High or Open (1st stage)	Ignition switch: ON	Restraints Control Module (RCM) detected that the resistance of RCM connector terminals is out of the specification range.	<ul style="list-style-type: none"> • Driver airbag module • Spiral cable • Driver airbag module connector • Harness is open between spiral cable and RCM • RCM

FIRING LOOP RESISTANCE FOR DRIVER FRONT AIRBAG

COMPONENT	MIN.	NOMINAL	MAX.
Squib (Rs)	1.8 Ω	2.0 Ω	2.2 Ω
Contact Coil (Rc)	0.232 Ω	0.29 Ω	0.348 Ω
Wiring Harness (Rw)	0 Ω	0 Ω	0.2 Ω
Connector Terminals (Rt)	0 Ω	0 Ω </td <td>0.05 Ω</td>	0.05 Ω
Total Resistance	2.032 Ω	2.29 Ω	2.798 Ω

FIRING LOOP FOR DRIVER FRONT AIRBAG

DESCRIPTION	
1: Rw - Wiring harness resistance	<p style="text-align: right;">Itsmd140008</p>
2: Rc - Contact coil resistance	
3: Rs + Rt - Squib resistance + terminal resistance	
4: Squib for Driver - side front airbag inflator	
5: Contact coil	
6: Wiring harness	
7: HAE 3.5	
$R(DAB) = R_s + R_t + R_w + R_c$	

DIAGNOSIS & TESTING

TEST FOR DRIVER FRONT AIRBAG FIRING LOOP DIAGNOSIS		
RESISTANCE RANGE	DESCRIPTION	FAULT INDICATION
$R(DAB) < 1.06 \Omega$	Resistance too low or short	Fault definitely detected
$1.80 \Omega \leq R(DAB) < 4.84 \Omega$	Normal	No fault
$7.28 \Omega \leq R(DAB)$	Resistance too high	Fault definitely detected
$1.06 \Omega < R(DAB) < 1.80 \Omega$ $4.84 \Omega < R(DAB) < 7.28 \Omega$	Tolerance	Fault may or may not be detected

DTC Confirmation Procedure:

Before performing the following procedure, confirm that battery voltage is more than 12 V.

- Turn ignition switch off.
- Connect the X-431 scan tool to the Data Link Connector (DLC) - use the latest software available.
- Turn ignition switch on.
- With the scan tool, record and erase stored DTCs in the RCM.
- Turn ignition switch off and wait for a few seconds.
- Turn ignition switch on then select view DTC.
- If the DTC is detected, the DTC condition is current. Go to Diagnostic Procedure - Step 1.
- If the DTC is not detected, the DTC condition is intermittent (See Diagnostic Help and Intermittent DTC Troubleshooting in Section 14 Restraints for more information).

Diagnostic Guide Lines

Observe the following guide lines while diagnosing this DTC:

- Troubleshoot any Engine Control Module (ECM) charging/cranking DTCs before proceeding.
- If the warning lamp goes out immediately after the warning lamp flashed for 6 - 7 seconds, this indicates that the system is OK.
- If the warning lamp is on for 6 - 7 seconds continuously, then goes out, or the warning lamp is on continuously, this indicates that there are history DTCs in the system. Use the Scan Tool to erase the DTCs.
- If any other condition occurs, use the Scan Tool to erase the history DTCs first, then check the warning lamp. If the warning lamp does not go out immediately after the warning lamp flashes for 6 - 7 seconds when using the Scan Tool, erase the history DTCs first.
- In the course of troubleshooting the airbag system, make sure the system power supply is shut off, and wait two minutes for the system capacitor to discharge.
- The squib circuit connectors integrate a "shorting" spring (which prevents the airbag from deploying unintentionally due to static electricity by shorting the positive wire to the negative wire in the squib circuit when the connectors are disconnected). Therefore, if the airbag electrical connector or spiral cable electrical connector is damaged or improperly connected, the shorting spring may not be released when the electrical connector is connected.
- The following tools are required to perform the DTC diagnostic procedure:
 - X-431 Scan Tool
 - Airbag Special Load Tool
 - Digital Multimeter

NOTE :

While performing electrical diagnosis & testing, always refer to the electrical schematics for specific circuit and component information.

DIAGNOSIS & TESTING

Diagnostic Procedure

1. CHECK RCM DTC

- Perform the DTC confirmation procedure.

Is DTC B1346 present?

Yes >> Go to the next step.

No >> Go to Step 6.

2. CHECK DRIVER AIRBAG MODULE

- Turn ignition switch off.
- Disconnect the negative battery cable.

WARNING!

To avoid serious or fatal injury, turn ignition switch off, disconnect the negative battery cable and wait two minutes before proceeding.

- Disconnect the driver airbag module electrical connector J-003.

NOTE :

Check connectors - Clean and repair as necessary.

- Connect the airbag special load tool to the spiral cable side of the vehicle harness (connect the special tool resistor (2 ohms) in place of the passenger airbag module).

WARNING!

To avoid serious or fatal injury, the driver airbag module should not be checked with a multimeter.

NOTE :

If the airbag special load tool is not available, connect a known good driver airbag module.

- Connect the negative battery cable.

WARNING!

To avoid serious or fatal injury, reconnect the battery, then turn ignition switch on.

- Turn ignition switch on.
- With the scan tool, erase the DTC in the RCM.
- Turn ignition switch off, and wait a few seconds, then turn ignition switch on.
- With the scan tool, read the RCM DTCs

Is DTC B1346 present?

Yes >> Go to the next step.

No >> Replace the driver airbag module (See Driver Airbag Module Removal & Installation in Section 14 Restraints).
Reassemble the vehicle and road test to verify the customers complaint is repaired.

3. CHECK DRIVER AIRBAG MODULE CONTROL CIRCUITS

WARNING!

To avoid serious or fatal injury, turn the ignition switch off, disconnect the negative battery cable and wait two minutes before proceeding.

DIAGNOSIS & TESTING

- Disconnect the airbag special load tool.
- Disconnect the RCM connector J-001 (1) (See Restraints Control Module (RCM) Removal & Installation in Section 14 Restraints).
- Disconnect the spiral cable electrical connector J-005.

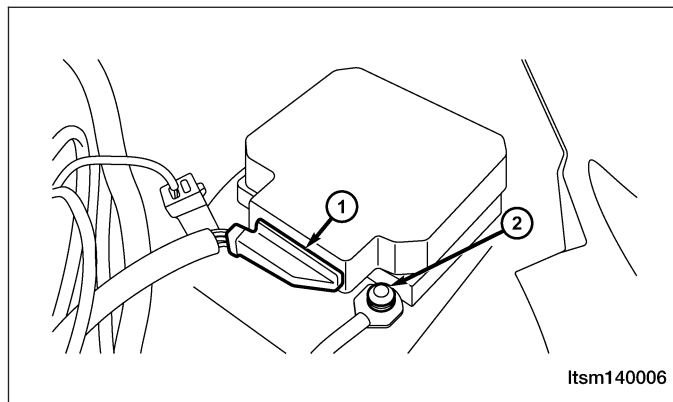

NOTE :

Check connectors - Clean and repair as necessary.

- Check the harness for continuity of the driver airbag circuit between terminal 10 in the RCM electrical connector J-001 terminal side and terminal 1 in the spiral cable electrical connector J-005 terminal side.
- Continuity should exist.

CHECK CONTINUITY			
SPIRAL CABLE TERMINAL	RCM TERMINAL	CONTINUITY	
1	10	Yes	

- Check the harness for continuity of the driver airbag circuit between terminal 11 in the RCM electrical connector J-001 and terminal 2 in the spiral cable electrical connector J-005 terminal side.
- Continuity should exist.

CHECK CONTINUITY			
SPIRAL CABLE TERMINAL	RCM TERMINAL	CONTINUITY	
2	11	Yes	

- The resistance should be less than 0.2 Ω.

Is the check result normal?

Yes >> Go to the next step.

No >> Replace the cable.

DIAGNOSIS & TESTING

4. CHECK DRIVER AIRBAG MODULE CONTROL CIRCUITS

WARNING!

To avoid serious or fatal injury, turn the ignition switch off, disconnect the negative battery cable and wait two minutes before proceeding.

- Disconnect the driver airbag module connectors.

NOTE :

Check connectors - Clean and repair as necessary.

- Check the harness for continuity of the driver airbag circuit between terminal 1 in the driver airbag module electrical connector J-003 and terminal 1 in the spiral cable electrical connector J-005 terminal side.
- Continuity should exist.

CHECK CONTINUITY			
SPIRAL CABLE TERMINAL	DRIVER AIRBAG MODULE TERMINAL	CONTINUITY	
1	1	Yes	<p style="text-align: right;">Itsmd140004</p>

- Check the harness for continuity of the driver airbag circuit between the driver airbag module electrical connector terminal 2 and the spiral cable electrical connector terminal 2.
- Continuity should exist.

CHECK CONTINUITY			
SPIRAL CABLE TERMINAL	DRIVER AIRBAG MODULE TERMINAL	CONTINUITY	
2	2	Yes	<p style="text-align: right;">Itsmd140005</p>

Is the check result normal?

Yes >> Go to the next step.

No >> Replace the spiral cable.

5. CHECK CONNECTORS

NOTE :

Diagnose and repair all active codes before diagnosing stored codes (See Restraints Control Module DTC List in Section 14 Restraints).

- With the scan tool, record and erase all RCM DTCs.
- Using the electrical schematic as a guide, inspect the following:
 - Inspect the wiring and connectors of the related airbag system.
 - Look for any chafed, pierced, pinched, or partially broken wires.
 - Look for broken, bent, pushed out or corroded terminals.
 - Verify that there is good pin to terminal contact in the related connectors.

Were any problems found?

Yes >> Repair as necessary.

No >> Go to the next step.

6. CHECK DTC

- Reconnect all disconnected components and harness connectors.
- With the X-431 scan tool, read RCM DTCs.
- Refer to "DTC Confirmation Procedure".

Is DTC B1346 still present?

Yes >> Replace the RCM.

No >> The system is now operating properly.
Reassemble the vehicle and road test to verify the customers complaint is repaired.

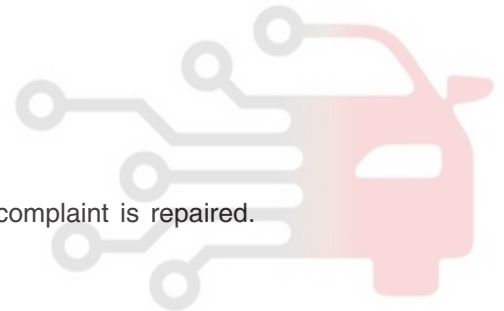

اولین سامانه دیجیتال تعمیرکاران خودرو در ایران

DIAGNOSIS & TESTING

B1352 - Passenger Airbag Resistance Too High Or Open (1st Stage)



دیجیتال خودرو
 شرکت دیجیتال خودرو سامانه (مسئولیت محدود)
 اولین سامانه دیجیتال تعمیرکاران خودرو در ایران

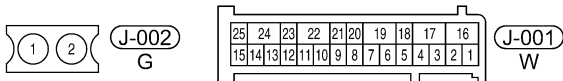

DIAGNOSIS & TESTING

NOTE :

The Restraints Control Module (RCM) ground pin must be connected to the vehicle chassis in the immediate location of the RCM mounting area.

WARNING!

After installing the Restraints Control Module (RCM), make sure all of the connectors are firmly connected, and the harness is routed properly. The resistance between the RCM housing and the vehicle body should be less than 100 mΩ.

On Board Diagnostic Logic

- Self-diagnosis detection logic.

DTC NO.	DTC DEFINITION	DTC DETECTION CONDITION	DTC SET CONDITION	POSSIBLE CAUSE
B1352	Passenger Airbag Resistance Too High Or Open (1st Stage)	Ignition switch: ON	Restraints Control Module (RCM) detected that the resistance of RCM connector terminals is out of the specification range.	<ul style="list-style-type: none"> • Passenger airbag module • Spiral cable • Passenger airbag module connector • Harness is open between passenger airbag module and RCM • RCM

FIRING LOOP RESISTANCE FOR PASSENGER FRONT AIRBAG

COMPONENT	MIN.	NOMINAL	MAX.
Squib (Rs)	1.7 Ω	2.0 Ω	2.3 Ω
Wiring Harness (Rw)	0 Ω	0 Ω	0.2 Ω
Connector Terminals (Rt)	0 Ω	0 Ω	0.05 Ω
Total Resistance	1.7 Ω	2.0 Ω	2.55 Ω

TEST FOR PASSENGER FRONT AIRBAG FIRING LOOP DIAGNOSIS

RESISTANCE RANGE: $R(DAB) = R_s + R_t + R_w$	DESCRIPTION	FAULT INDICATION
$R(DAB) < 0.4 \Omega$	Resistance too low or short to GND	Fault definitely detected
$1.60 \Omega \leq R(DAB) < 4.84 \Omega$	Normal	No fault
$7.28 \Omega \leq R(DAB)$	Resistance too high	Fault definitely detected
$0.4 \Omega < R(DAB) < 1.60 \Omega$ $4.84 \Omega < R(DAB) < 7.28 \Omega$	Tolerance	Fault may or may not be detected

DIAGNOSIS & TESTING

FIRING LOOP FOR PASSENGER FRONT AIRBAG	
DESCRIPTION	<p style="text-align: right;">Itsmd140008</p>
1: R _w - Wiring harness resistance	
2: R _c - Contact coil resistance	
3: R _s + R _t - Squib resistance + terminal resistance	
4: Squib for passenger - side front airbag inflator	
5: Contact coil	
6: Wiring harness	
7: HAE 3.5	
$R(DAB) = R_s + R_t + R_w$	

DTC Confirmation Procedure:

Before performing the following procedure, confirm that battery voltage is more than 12 V.

- Turn ignition switch off.
- Connect the X-431 scan tool to the Data Link Connector (DLC) - use the latest software available.
- Turn ignition switch on.
- With the scan tool, record and erase stored DTCs in the RCM.
- Turn ignition switch off and wait for a few seconds.
- Turn ignition switch on then select view DTC.
- If the DTC is detected, the DTC condition is current. Go to Diagnostic Procedure - Step 1.
- If the DTC is not detected, the DTC condition is intermittent (See Diagnostic Help and Intermittent DTC Troubleshooting in Section 14 Restraints for more information).

Diagnostic Guide Lines

Observe the following guide lines while diagnosing this DTC:

- Troubleshoot any Engine Control Module (ECM) charging/cranking DTCs before proceeding.
- If the warning lamp goes out immediately after the warning lamp flashed for 6 - 7 seconds, this indicates that the system is OK.
- If the warning lamp is on for 6 - 7 seconds continuously, then goes out, or the warning lamp is on continuously, this indicates that there are history DTCs in the system. Use the Scan Tool to erase the DTCs.
- If any other condition occurs, use the Scan Tool to erase the history DTCs first, then check the warning lamp. If the warning lamp does not go out immediately after the warning lamp flashes for 6 - 7 seconds when using the Scan Tool, erase the history DTCs first.
- In the course of troubleshooting the airbag system, make sure the system power supply is shut off, and wait two minutes for the system capacitor to discharge.
- The squib circuit connectors integrate a "shorting" spring (which prevents the airbag from deploying unintentionally due to static electricity by shorting the positive wire to the negative wire in the squib circuit when the connectors are disconnected). Therefore, if the airbag electrical connector or spiral cable electrical connector is damaged or improperly connected, the shorting spring may not be released when the electrical connector is connected.
- The following tools are required to perform the DTC diagnostic procedure:
 - X-431 Scan Tool
 - Airbag Special Load Tool
 - Digital Multimeter

NOTE :

While performing electrical diagnosis & testing, always refer to the electrical schematics for specific circuit and component information.

DIAGNOSIS & TESTING

Diagnostic Procedure

1. CHECK RCM DTC

- With the scan tool X-431, view DTCs in the RCM.

Is DTC B1352 present?

Yes >> Go to the next step.

No >> Go to step 6.

2. CHECK FRONT PASSENGER AIRBAG MODULE

- Turn ignition switch off.
- Disconnect the negative battery cable.

WARNING!

To avoid serious or fatal injury, turn ignition switch off, disconnect the negative battery cable and wait two minutes before proceeding.

- Disconnect the passenger airbag module electrical connector.

NOTE :

Check connectors - Clean and repair as necessary.

- Connect the airbag special load tool to the spiral cable side of the vehicle harness (connect the special tool resistor (2 Ω) in place of the passenger airbag module).
- Connect the negative battery cable.

WARNING!

To avoid serious or fatal injury, the passenger airbag module should not be checked by multimeter.

NOTE :

If the airbag special load tool is not available, connect a known good passenger airbag module.

WARNING!

To avoid serious or fatal injury, reconnect the battery, then turn ignition switch on.

- Turn ignition switch on.
- With the scan tool, erase the DTC memory.
- Turn ignition switch off, and wait a few seconds, then turn ignition switch on.
- With the scan tool, read the RCM DTCs

Is DTC B1352 present?

Yes >> Go to the next step.

No >> Replace the passenger airbag module (See Passenger Airbag Module Removal & Installation in Section 14 Restraints).
Reassemble the vehicle and road test to verify the customer's complaint is repaired.

3. CHECK PASSENGER AIRBAG MODULE CONTROL CIRCUITS

WARNING!

To avoid serious or fatal injury, turn ignition switch off, disconnect the negative battery cable and wait two minutes before proceeding.

DIAGNOSIS & TESTING

- Disconnect the airbag special load tool.
- Disconnect the RCM connector (1) (See Restraints Control Module (RCM) Removal & Installation in Section 14 Restraints).

NOTE :

- Check connectors - Clean and repair as necessary.
- Check the harness for continuity of the passenger airbag circuit between terminal 13 in the RCM electrical connector J-001 terminal side and terminal 1 in the passenger airbag electrical connector J-002 terminal side.
 - Continuity should exist.

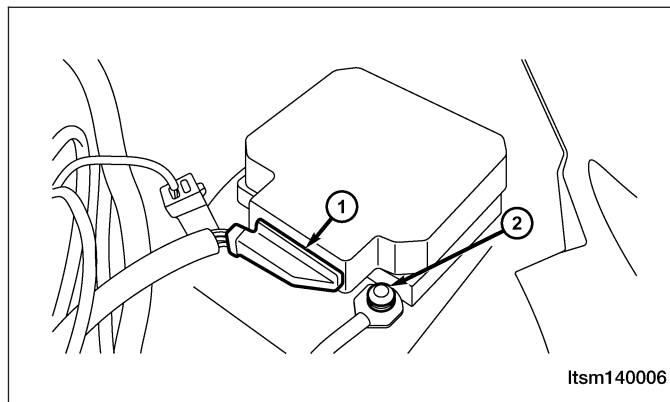

CHECK CONTINUITY			
FRONT PASSENGER AIRBAG TERMINAL	RCM TERMINAL	CONTINUITY	
1	13	Yes	

Itsmd140006

- Check the harness for continuity of the passenger airbag circuit between terminal 14 in the RCM electrical connector J-001 terminal side and terminal 2 in the passenger airbag electrical connector J-002 terminal side.
- Continuity should exist.

CHECK CONTINUITY			
FRONT PASSENGER AIRBAG TERMINAL	RCM TERMINAL	CONTINUITY	
2	14	Yes	

Itsmd140007

Is the check result normal?

Yes >> Go to the next step.

No >> Replace the spiral cable.

4. CHECK CONNECTORS

NOTE :

Diagnose and repair all active codes before diagnosing stored codes (See Restraints Control Module DTC List in Section 14 Restraints).

- With the scan tool, record and erase all RCM DTCs.
- Using the electrical schematic as a guide, inspect the following:
 - Inspect the wiring and connectors of the related airbag system.
 - Look for any chafed, pierced, pinched, or partially broken wires.
 - Look for broken, bent, pushed out or corroded terminals.
 - Verify that there is good pin to terminal contact in the related connectors.

Were any problems found?

Yes >> Repair as necessary.

No >> Go to the next step.

5. CHECK DTC

- Reconnect all disconnected components and harness connectors.
- With the X-431 scan tool, read RCM DTCs.
- Refer to "DTC Confirmation Procedure".

Is DTC B1352 still present?

Yes >> Replace the RCM.

No >> The system is now operating properly.
Reassemble the vehicle and road test to verify the customers complaint is repaired.

اولین سامانه دیجیتال تعمیرکاران خودرو در ایران

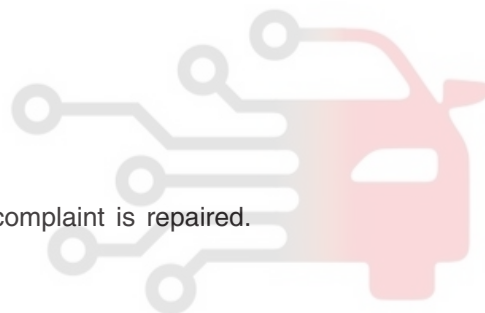

DIAGNOSIS & TESTING

B2501 - Warning Lamp Fault-Open

SRC - DIAG - 01

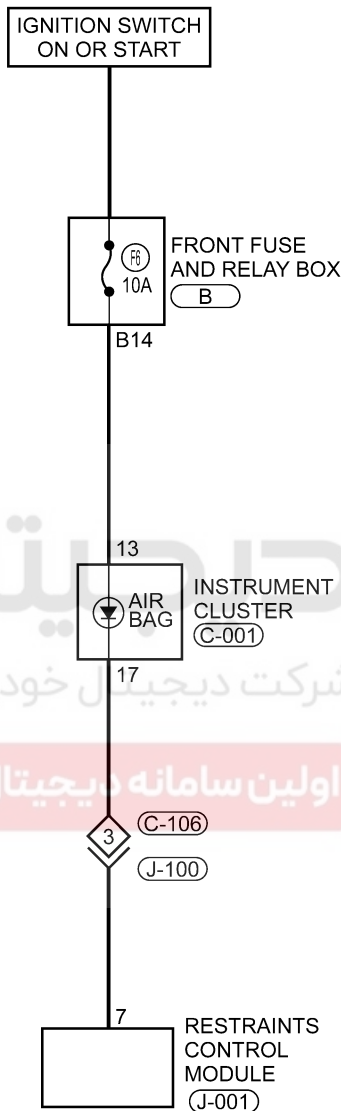

دیجیتال خودرو
 شرکت دیجیتال خودرو سامانه (مسئولیت محدود)
 اولین سامانه دیجیتال تعمیرکاران خودرو در ایران



B1	B2	B3	B4	B5	B6	B7	B8
B9	B10	B11	B12	B13	B14	B15	B16
B17	B18	B19	B20	B			

BODY FUSE AND RELAY BOX
 W

17	18	19	20	21	22	23	24	25	26	27	28	29	30	31	32
1	2	3	4	5	6	7	8	9	10	11	12	13	14	15	16

C-001
 L

2		1	J-100	
6	5	4	3	W

25	24	23	22	21	20	19	18	17	16					
15	14	13	12	11	10	9	8	7	6	5	4	3	2	1

J-001
 W

DIAGNOSIS & TESTING

NOTE :

The Restraints Control Module (RCM) ground pin must be connected to the vehicle chassis in the immediate location of the RCM mounting area.

WARNING!

After installing the Restraints Control Module (RCM), make sure all of the connectors are firmly connected, and the harness is routed properly. The resistance between the RCM housing and the vehicle body should be less than 100 mΩ.

On Board Diagnostic Logic

- Self-diagnosis detection logic.

DTC NO.	DTC DEFINITION	DTC DETECTION CONDITION	DTC SET CONDITION	POSSIBLE CAUSE
B2501	Warning Lamp Fault - Open	Ignition switch: ON	This DTC will set if the airbag warning lamp driver circuit is shorted to ground or open between the airbag warning lamp and the Restraints Control Module (RCM).	<ul style="list-style-type: none"> • Instrument cluster • Harness is open between instrument cluster and RCM • RCM

DTC Confirmation Procedure:

Before performing the following procedure, confirm that battery voltage is more than 12 V.

- Turn ignition switch off.
- Connect the X-431 scan tool to the Data Link Connector (DLC) - use the latest software available.
- Turn ignition switch on.
- With the scan tool, record and erase stored DTCs in the RCM.
- Turn ignition switch off and wait for a few seconds.
- Turn ignition switch on then select view DTC.
- If the DTC is detected, the DTC condition is current. Go to Diagnostic Procedure - Step 1.
- If the DTC is not detected, the DTC condition is intermittent (See Diagnostic Help and Intermittent DTC Troubleshooting in Section 14 Restraints for more information).

Diagnostic Guide Lines

Observe the following guide lines while diagnosing this DTC:

- Troubleshoot any Engine Control Module (ECM) charging/cranking DTCs before proceeding.
- If the warning lamp goes out immediately after the warning lamp flashed for 6 - 7 seconds, this indicates that the system is OK.
- If the warning lamp is on for 6 - 7 seconds continuously, then goes out, or the warning lamp is on continuously, this indicates that there are history DTCs in the system. Use the Scan Tool to erase the DTCs.
- If any other condition occurs, use the Scan Tool to erase the history DTCs first, then check the warning lamp. If the warning lamp does not go out immediately after the warning lamp flashes for 6 - 7 seconds when using the Scan Tool, erase the history DTCs first.
- In the course of troubleshooting the airbag system, make sure the system power supply is shut off, and wait two minutes for the system capacitor to discharge.
- The squib circuit connectors integrate a "shorting" spring (which prevents the airbag from deploying unintentionally due to static electricity by shorting the positive wire to the negative wire in the squib circuit when the connectors are disconnected). Therefore, if the airbag electrical connector or spiral cable electrical connector is damaged or improperly connected, the shorting spring may not be released when the electrical connector is connected.
- The following tools are required to perform the DTC diagnostic procedure:
 - X-431 Scan Tool
 - Airbag Special Load Tool
 - Digital Multimeter

DIAGNOSIS & TESTING

NOTE :

While performing electrical diagnosis & testing, always refer to the electrical schematics for specific circuit and component information.

Diagnostic Procedure

1. CHECK RCM DTC

- Connect the X-431 scan tool to the Data Link Connector (DLC) - use the most current software available.
- Turn the ignition switch on, with the scan tool, view and erase stored DTCs in the RCM.
- Turn the ignition switch off, and wait a few seconds, then turn the ignition switch on.
- Wait one minute, and with the scan tool, view active DTCs in the RCM.

Is DTC B2501 present?

Yes >> Go to the next step.

No >> Go to step 5.

2. CHECK WARNING LAMP

- Turn ignition switch off, and wait a few seconds, then turn ignition switch on.
- Observe the airbag warning lamp.

Is the airbag warning lamp not illuminated with the ignition switch ON?

Yes >> Go to the next step.

No >> Go to step 4.

3. CHECK WARNING LAMP CIRCUITS

WARNING! اولین سامانه دیجیتال تعمیرکاران خودرو

To avoid serious or fatal injury, turn ignition switch off, disconnect the negative battery cable and wait two minutes before proceeding.

- Disconnect the RCM electrical connector (1) (See Restraints Control Module (RCM) Removal & Installation in Section 14 Restraints).
- Disconnect the instrument cluster electrical connector.
- Disconnect the front fuse and relay box electrical connector B14.

NOTE :

Check connectors - Clean and repair as necessary.

- Check fuse F6.
- Measure the following circuits with a digital multimeter:
 - Harness connector C-106, J-100.
 - Harness for an open between the front fuse and relay box electrical connector (terminal B4, B14) and instrument cluster C-001 (terminal 11 and 13).
 - Harness for open between the instrument cluster C-001 (terminal 17) and RCM electrical connector J-001 (terminal 7).
- Check the harness for continuity.

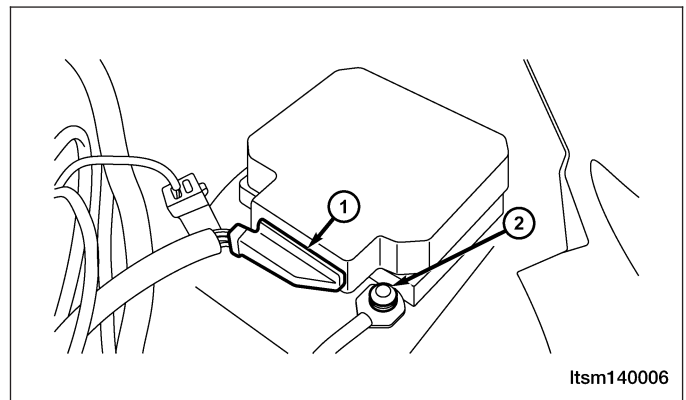

DIAGNOSIS & TESTING

- Continuity should exist.

Is the check result normal?

Yes >> Replace the instrument cluster.
If DTC is still present, Go to the next step.

No >> Repair the harness wires between the RCM electrical connector J-001 (terminal 7) and instrument cluster C-001 (terminal 17) and the harness wires between combination meter C-001 (terminal 13) and front fuse and relay box electrical connector (terminal B14) for an open.

4. CHECK CONNECTORS

NOTE :

Diagnose and repair all active codes before diagnosing stored codes (See Restraints Control Module DTC List in Section 14 Restraints).

- With the scan tool, record and erase all RCM DTCs.
- Using the electrical schematic as a guide, inspect the following:
 - Inspect the wiring and connectors of the related airbag system.
 - Look for any chafed, pierced, pinched, or partially broken wires.
 - Look for broken, bent, pushed out or corroded terminals.
 - Verify that there is good pin to terminal contact in the related connectors.

Were any problems found?

Yes >> Repair as necessary.

No >> Go to the next step.

5. CHECK DTC

- Reconnect all disconnected components and harness connectors.
- With the X-431 scan tool, read RCM DTCs.
- Refer to "DTC Confirmation Procedure".

Is DTC B2501 still present?

Yes >> Replace the RCM.

No >> The system is now operating properly.
Reassemble the vehicle and road test to verify the customers complaint is repaired.

DIAGNOSIS & TESTING

B2503 - Warning Lamp Fault-Short To Ground

SRC - DIAG - 01

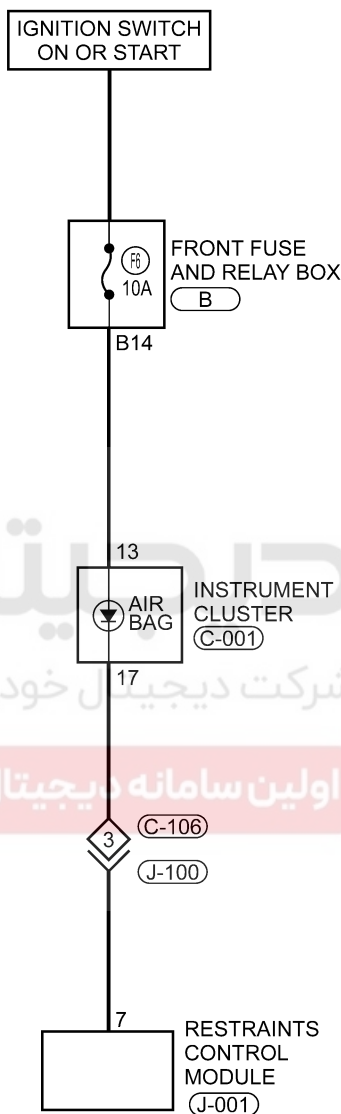

دیجیتال خودرو
 شرکت دیجیتال خودرو سامانه (مسئولیت محدود)
 اولین سامانه دیجیتال تعمیرکاران خودرو در ایران



B1	B2	B3	B4	B5	B6	B7	B8
B9	B10	B11	B12	B13	B14	B15	B16
B17	B18	B19	B20	B			
W							

BODY FUSE AND RELAY BOX

17	18	19	20	21	22	23	24	25	26	27	28	29	30	31	32
1	2	3	4	5	6	7	8	9	10	11	12	13	14	15	16

C-001 L

2		1	J-100	
6	5	4	3	W

25	24	23	22	21	20	19	18	17	16
15	14	13	12	11	10	9	8	7	6
5	4	3	2	1	J-001				
W									

DIAGNOSIS & TESTING

NOTE :

The Restraints Control Module (RCM) ground pin must be connected to the vehicle chassis in the immediate location of the RCM mounting area.

WARNING!

After installing the Restraints Control Module (RCM), make sure all of the connectors are firmly connected, and the harness is routed properly. The resistance between the RCM housing and the vehicle body should be less than 100 mΩ.

On Board Diagnostic Logic

- Self-diagnosis detection logic.

DTC NO.	DTC DEFINITION	DTC DETECTION CONDITION	DTC SET CONDITION	POSSIBLE CAUSE
B2503	Warning Lamp Fault - Short To Ground	Ignition switch: ON	This DTC will set if the airbag warning lamp driver circuit is shorted to ground between the airbag warning lamp and the Restraints Control Module (RCM).	<ul style="list-style-type: none"> • Instrument cluster • Harness is shorted to ground between instrument cluster and RCM • RCM

DTC Confirmation Procedure:

Before performing the following procedure, confirm that battery voltage is more than 12 V.

- Turn ignition switch off.
- Connect the X-431 scan tool to the Data Link Connector (DLC) - use the latest software available.
- Turn ignition switch on.
- With the scan tool, record and erase stored DTCs in the RCM.
- Turn ignition switch off and wait for a few seconds.
- Turn ignition switch on then select view DTC.
- If the DTC is detected, the DTC condition is current. Go to Diagnostic Procedure - Step 1.
- If the DTC is not detected, the DTC condition is intermittent (See Diagnostic Help and Intermittent DTC Troubleshooting in Section 14 Restraints for more information).

Diagnostic Guide Lines

Observe the following guide lines while diagnosing this DTC:

- Troubleshoot any Engine Control Module (ECM) charging/cranking DTCs before proceeding.
- If the warning lamp goes out immediately after the warning lamp flashed for 6 - 7 seconds, this indicates that the system is OK.
- If the warning lamp is on for 6 - 7 seconds continuously, then goes out, or the warning lamp is on continuously, this indicates that there are history DTCs in the system. Use the Scan Tool to erase the DTCs.
- If any other condition occurs, use the Scan Tool to erase the history DTCs first, then check the warning lamp. If the warning lamp does not go out immediately after the warning lamp flashes for 6 - 7 seconds when using the Scan Tool, erase the history DTCs first.
- In the course of troubleshooting the airbag system, make sure the system power supply is shut off, and wait two minutes for the system capacitor to discharge.
- The squib circuit connectors integrate a "shorting" spring (which prevents the airbag from deploying unintentionally due to static electricity by shorting the positive wire to the negative wire in the squib circuit when the connectors are disconnected). Therefore, if the airbag electrical connector or spiral cable electrical connector is damaged or improperly connected, the shorting spring may not be released when the electrical connector is connected.
- The following tools are required to perform the DTC diagnostic procedure:
 - X-431 Scan Tool
 - Airbag Special Load Tool
 - Digital Multimeter

DIAGNOSIS & TESTING

NOTE :

While performing electrical diagnosis & testing, always refer to the electrical schematics for specific circuit and component information.

Diagnostic Procedure

1. CHECK RCM DTC

- Connect the X-431 scan tool to the Data Link Connector (DLC) - use the most current software available.
- Turn the ignition switch on, with the scan tool, view and erase stored DTCs in the RCM.
- Turn the ignition switch off, and wait a few seconds, then turn the ignition switch on.
- Wait one minute, and with the scan tool, view active DTCs in the RCM.

Is DTC B2503 present?

Yes >> Go to the next step.

No >> Go to step 5.

2. CHECK WARNING LAMP

- Turn ignition switch off, and wait a few seconds, then turn ignition switch on.
- Observe the airbag warning lamp.

Is the airbag warning lamp illuminated constantly with the ignition ON?

Yes >> Go to the next step.

No >> Go to step 4.

3. CHECK WARNING LAMP CIRCUITS

WARNING! اولین سامانه دیجیتال تعمیرکاران خودرو (مسئولیت محدود)

To avoid serious or fatal injury, turn ignition switch off, disconnect the negative battery cable and wait two minutes before proceeding.

- Disconnect the RCM electrical connector (1) (See Restraints Control Module (RCM) Removal & Installation in Section 14 Restraints).
- Disconnect the instrument cluster electrical connector.
- Disconnect the front fuse and relay box electrical connector B14.

NOTE :

Check connectors - Clean and repair as necessary.

- Check fuse F6.
- Measure the following circuits with a digital multimeter:
 - Harness for a short to ground between the front fuse and relay box electrical connector (terminal B14) and instrument cluster C-001 (terminal 13).
 - Harness for a short to ground between the instrument cluster C-001 (terminal 17) and RCM electrical connector J-001 (terminal 7).
 - Harness connector C-106, J-100.

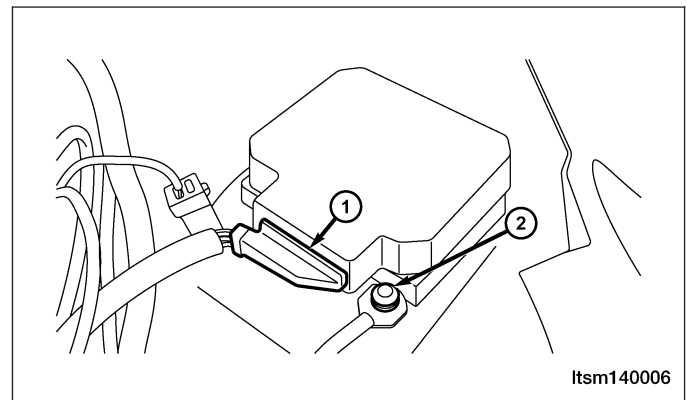

DIAGNOSIS & TESTING

- The harness continuity between the front fuse and relay box electrical connector (terminal B14) and RCM electrical connector J-001 (terminal 7) should not exist.

Is the check result normal?

- Yes** >> Replace the instrument cluster.
If DTC is still present, go the next step.
- No** >> Repair the harness between the RCM electrical connector J-001 (terminal 7) and instrument cluster C-001 (terminal 17) and the harness between combination meter C-001 (terminal 13) and front fuse and relay box electrical connector (terminal B14) for an short to ground.

4. CHECK CONNECTORS

NOTE :

Diagnose and repair all active codes before diagnosing stored codes (See Restraints Control Module DTC List in Section 14 Restraints).

- With the scan tool, record and erase all RCM DTCs.
- Using the electrical schematic as a guide, inspect the following:
 - Inspect the wiring and connectors of the related airbag system.
 - Look for any chafed, pierced, pinched, or partially broken wires.
 - Look for broken, bent, pushed out or corroded terminals.
 - Verify that there is good pin to terminal contact in the related connectors.

Were any problems found?

- Yes** >> Repair as necessary.
- No** >> Go to the next step.

شرکت دیجیتال خودرو سامانه (مسئولیت محدود)

5. CHECK DTC

- Reconnect all disconnected components and harness connectors.
- With the X-431 scan tool, read RCM DTCs.
- Refer to "DTC Confirmation Procedure".

Is DTC B2503 still present?

- Yes** >> Replace the RCM.
- No** >> The system is now operating properly.
Reassemble the vehicle and road test to verify the customers complaint is repaired.

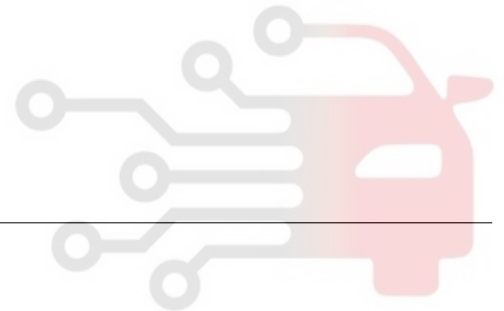

DIAGNOSIS & TESTING

B2504 - Warning Lamp Fault-Short To Battery

SRC - DIAG - 01

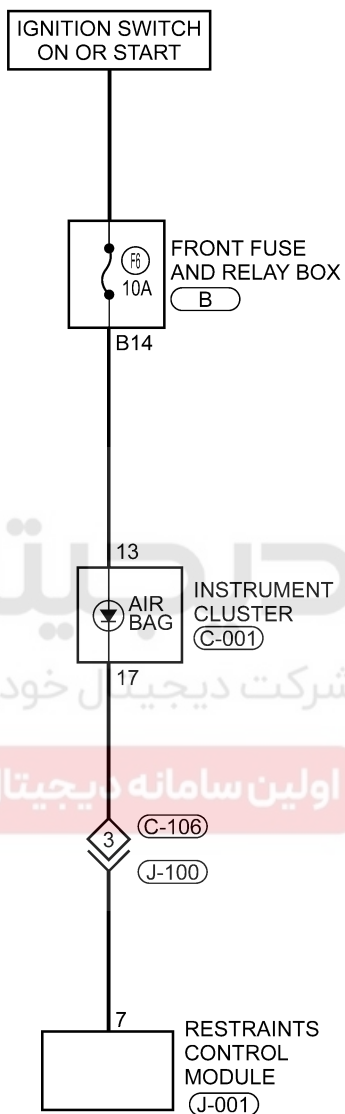

دیجیتال خودرو
 شرکت دیجیتال خودرو سامانه (مسئولیت محدود)
 اولین سامانه دیجیتال تعمیرکاران خودرو در ایران

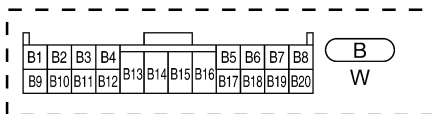

BODY FUSE AND RELAY BOX
 W

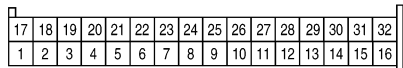

C-001
 L

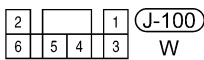

J-100
 W

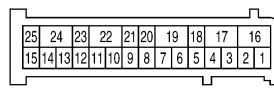

J-001
 W

DIAGNOSIS & TESTING

NOTE :

The Restraints Control Module (RCM) ground pin must be connected to the vehicle chassis in the immediate location of the RCM mounting area.

WARNING!

After installing the Restraints Control Module (RCM), make sure all of the connectors are firmly connected, and the harness is routed properly. The resistance between the RCM housing and the vehicle body should be less than 100 mΩ.

On Board Diagnostic Logic

- Self-diagnosis detection logic.

DTC NO.	DTC DEFINITION	DTC DETECTION CONDITION	DTC SET CONDITION	POSSIBLE CAUSE
B2504	Warning lamp fault - short to battery	Ignition switch: ON	This DTC will set if the airbag warning lamp driver circuit is shorted to ground or open between the airbag warning lamp and the Restraints Control Module (RCM).	<ul style="list-style-type: none"> • Instrument cluster • Harness is open between instrument cluster and RCM • RCM

DTC Confirmation Procedure:

Before performing the following procedure, confirm that battery voltage is more than 12 V.

- Turn ignition switch off.
- Connect the X-431 scan tool to the Data Link Connector (DLC) - use the latest software available.
- Turn ignition switch on.
- With the scan tool, record and erase stored DTCs in the RCM.
- Turn ignition switch off and wait for a few seconds.
- Turn ignition switch on then select view DTC.
- If the DTC is detected, the DTC condition is current. Go to Diagnostic Procedure - Step 1.
- If the DTC is not detected, the DTC condition is intermittent (See Diagnostic Help and Intermittent DTC Troubleshooting in Section 14 Restraints for more information).

Diagnostic Guide Lines

Observe the following guide lines while diagnosing this DTC:

- Troubleshoot any Engine Control Module (ECM) charging/cranking DTCs before proceeding.
- If the warning lamp goes out immediately after the warning lamp flashed for 6 - 7 seconds, this indicates that the system is OK.
- If the warning lamp is on for 6 - 7 seconds continuously, then goes out, or the warning lamp is on continuously, this indicates that there are history DTCs in the system. Use the Scan Tool to erase the DTCs.
- If any other condition occurs, use the Scan Tool to erase the history DTCs first, then check the warning lamp. If the warning lamp does not go out immediately after the warning lamp flashes for 6 - 7 seconds when using the Scan Tool, erase the history DTCs first.
- In the course of troubleshooting the airbag system, make sure the system power supply is shut off, and wait two minutes for the system capacitor to discharge.
- The squib circuit connectors integrate a "shorting" spring (which prevents the airbag from deploying unintentionally due to static electricity by shorting the positive wire to the negative wire in the squib circuit when the connectors are disconnected). Therefore, if the airbag electrical connector or spiral cable electrical connector is damaged or improperly connected, the shorting spring may not be released when the electrical connector is connected.
- The following tools are required to perform the DTC diagnostic procedure:
 - X-431 Scan Tool
 - Airbag Special Load Tool
 - Digital Multimeter

DIAGNOSIS & TESTING

NOTE :

While performing electrical diagnosis & testing, always refer to the electrical schematics for specific circuit and component information.

Diagnostic Procedure

1. CHECK RCM DTC

- Perform the DTC confirmation procedure.

Is DTC B2504 present?

Yes >> Go to the next step.

No >> Go to step 5.

2. CHECK WARNING LAMP

- Turn ignition switch off, and wait a few seconds, then turn ignition switch on.
- Observe SRS warning lamp.

Is the SRS warning lamp not illuminated with ignition switch ON?

Yes >> Go to the next step.

No >> Go to step 4.

3. CHECK WARNING LAMP CIRCUITS

WARNING!

To avoid serious or fatal injury, turn ignition switch off, disconnect the negative battery cable and wait two minutes before proceeding.

- Disconnect the RCM electrical connector (1) (See Restraints Control Module (RCM) Removal & Installation in Section 14 Restraints).
- Disconnect the instrument cluster electrical connector.
- Disconnect the front fuse and relay box electrical connector B14.

NOTE :

Check connectors - Clean and repair as necessary.

- Check fuse F6.
- Measure the following circuits with a digital multimeter:
 - Harness connector C-106, J-100.
 - Harness for short to battery between the instrument cluster C-001 (terminal 17) and RCM electrical connector J-001 (terminal 7).

Is the voltage present?

Yes >> Repair the harness wires between the RCM electrical connector J-001 (terminal 7) and instrument cluster C-001 (terminal 17) and the harness wires between combination meter C-001 (terminal 13) and front fuse and relay box electrical connector (terminal B14) for an short to battery.

No >> Replace the instrument cluster.
If DTC is still present, go to the next step.

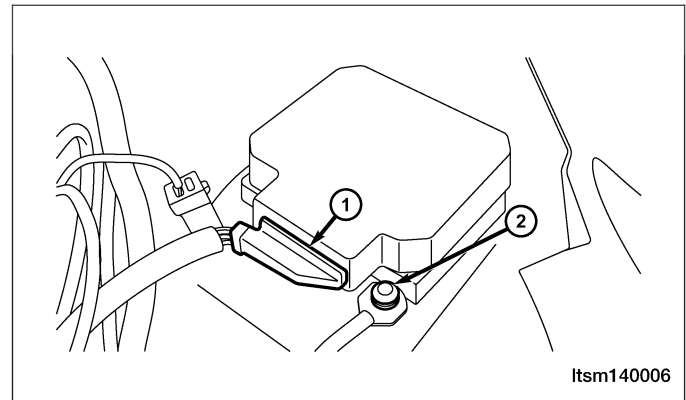

DIAGNOSIS & TESTING

4. CHECK CONNECTORS

NOTE :

Diagnose and repair all active codes before diagnosing stored codes (See Restraints Control Module DTC List in Section 14 Restraints).

- With the scan tool, record and erase all RCM DTCs.
- Using the electrical schematic as a guide, inspect the following:
 - Inspect the wiring and connectors of the related airbag system.
 - Look for any chafed, pierced, pinched, or partially broken wires.
 - Look for broken, bent, pushed out or corroded terminals.
 - Verify that there is good pin to terminal contact in the related connectors.

Were any problems found?

Yes >> Repair as necessary.

No >> Go to the next step.

5. CHECK DTC

- Reconnect all disconnected components and harness connectors.
- With the X-431 scan tool, read RCM DTCs.
- Refer to "DTC Confirmation Procedure".

Is DTC B2504 still present?

Yes >> Replace the RCM.

No >> The system is now operating properly.
Reassemble the vehicle and road test to verify the customers complaint is repaired.

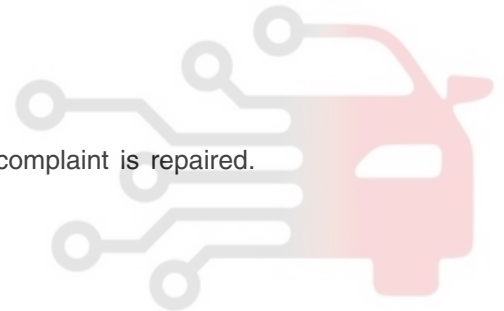

اولین سامانه دیجیتال تعمیرکاران خودرو در ایران

DIAGNOSIS & TESTING

B1620 - Internal Fault - Replace ECU

SRC - PWR - 01



دیجیتال خودرو
 شرکت دیجیتال خودرو سامانه (مسئولیت محدود)
 اولین سامانه دیجیتال تعمیرکاران خودرو در ایران

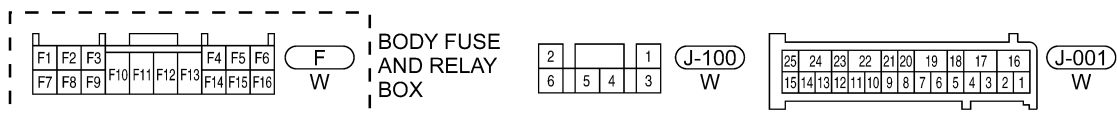

DIAGNOSIS & TESTING

SRC - PWR - 02

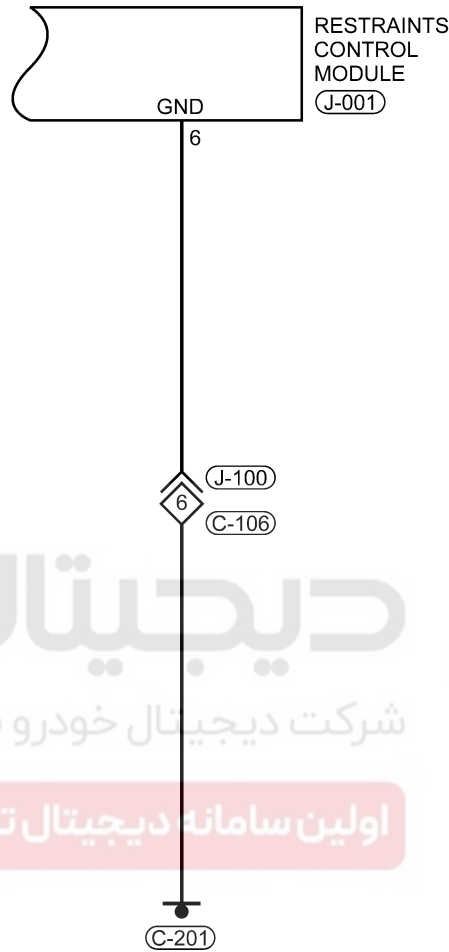

دیجیتال خودرو
شرکت دیجیتال خودرو سامانه (مسئولیت محدود)
اولین سامانه دیجیتال تعمیرکاران خودرو در ایران

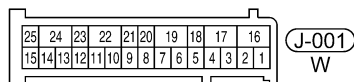
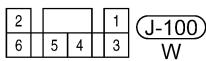

Itsmw140003t

DIAGNOSIS & TESTING**On Board Diagnostic Logic**

- Self-diagnosis detection logic.

DTC NO.	DTC DEFINITION	DTC DETECTION CONDITION	DTC SET CONDITION	POSSIBLE CAUSE
B1620	Internal Fault - Replace ECU	Ignition switch on	Restraints Control Module (RCM) detected an internal failure.	• RCM

DTC Confirmation Procedure:

Before performing the following procedure, confirm that battery voltage is more than 12 V.

- Turn ignition switch off.
- Connect the X-431 scan tool to the Data Link Connector (DLC) - use the latest software available.
- Turn ignition switch on.
- With the scan tool, record and erase stored DTCs in the RCM.
- Turn ignition switch off and wait for a few seconds.
- Turn ignition switch on then select view DTC.
- If the DTC is detected, the DTC condition is current. Go to Diagnostic Procedure - Step 1.
- If the DTC is not detected, the DTC condition is intermittent (See Diagnostic Help and Intermittent DTC Troubleshooting in Section 14 Restraints for more information).

Diagnostic Guide Lines

Observe the following guide lines while diagnosing this DTC:

- Troubleshoot any Engine Control Module (ECM) charging/cranking DTCs before proceeding.
- If the warning lamp goes out immediately after the warning lamp flashed for 6 - 7 seconds, this indicates that the system is OK.
- If the warning lamp is on for 6 - 7 seconds continuously, then goes out, or the warning lamp is on continuously, this indicates that there are history DTCs in the system. Use the Scan Tool to erase the DTCs.
- If any other condition occurs, use the Scan Tool to erase the history DTCs first, then check the warning lamp. If the warning lamp does not go out immediately after the warning lamp flashes for 6 - 7 seconds when using the Scan Tool, erase the history DTCs first.
- In the course of troubleshooting the airbag system, make sure the system power supply is shut off, and wait two minutes for the system capacitor to discharge.
- The squib circuit connectors integrate a "shorting" spring (which prevents the airbag from deploying unintentionally due to static electricity by shorting the positive wire to the negative wire in the squib circuit when the connectors are disconnected). Therefore, if the airbag electrical connector or spiral cable electrical connector is damaged or improperly connected, the shorting spring may not be released when the electrical connector is connected.
- The following tools are required to perform the DTC diagnostic procedure:
 - X-431 Scan Tool
 - Airbag Special Load Tool
 - Digital Multimeter

NOTE :

While performing electrical diagnosis & testing, always refer to the electrical schematics for specific circuit and component information.

DIAGNOSIS & TESTING

Diagnostic Procedure

1. CHECK DTC

- Perform the DTC confirmation procedure.

Is DTC B1620 present?

Yes >> Go to the next step.

No >> The condition that caused this DTC to set is currently not present (See Diagnostic Help and Intermittent DTC Troubleshooting in Section 14 Restraints for more information).

2. CHECK GROUND CONNECTION

- Turn ignition switch off.
- Disconnect the negative battery cable.
- Loosen and retighten ground screws on the body (See Ground Inspection in Section 14 Restraints for more information).
- Inspect the ground connection C-201 mounting position (See Vehicle Wiring Harness Layout - Main Harness in Section 16 Wiring).

Is the ground connection OK?

Yes >> Go to the next step.

No >> Repair or replace ground connection.

3. CHECK RESTRAINTS CONTROL MODULE (RCM) ELECTRICAL CONNECTOR

- Disconnect the Restraints Control Module (RCM) electrical connector (1).
- Inspect the electrical connector for damage.

Is the electrical connector OK?

Yes >> Go to the next step.

No >> Repair or replace the electrical connector as necessary.

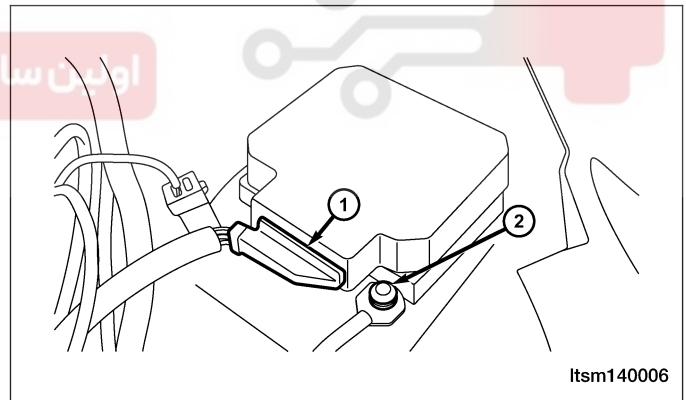

DIAGNOSIS & TESTING

4. CHECK RESTRAINTS CONTROL MODULE (RCM) POWER SUPPLY

- Turn ignition switch on.
- Check RCM power supply between terminal 5 and terminal 6 in the RCM electrical connector J-001 terminal side.

Is the voltage less than 9 V?

Yes >> Go to step 5.

No >> Replace the RCM.

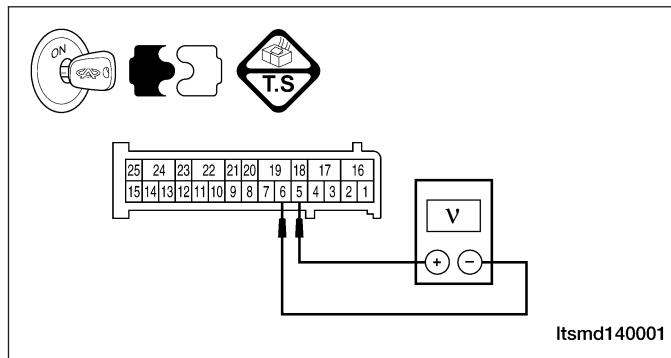

5. CHECK DTC

- With the X-431 scan tool, read RCM DTCs.
- Refer to "DTC Confirmation Procedure".

Is DTC B1620 still present?

Yes >> Replace the RCM.

No >> The system is now operating properly.
Reassemble the vehicle and road test to verify the customers complaint is repaired.

شرکت دیجیتال خودرو سامانه (مسئولیت محدود)

اولین سامانه دیجیتال تعمیرکاران خودرو در ایران

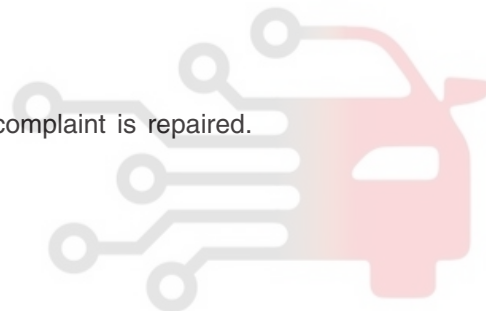

ON-VEHICLE SERVICE

Airbag System Disarming Procedure

Description

WARNING!

The steering column contains the driver's airbag. The airbag system is a sensitive, complex electro-mechanical unit. Before attempting to diagnose, remove or install the airbag system components, you must first disconnect and isolate the negative battery (ground) cable. Then wait two minutes for the system capacitor to discharge. Failure to do so could result in accidental deployment of the airbag and possible personal injury. The fasteners, screws, and bolts, originally used for the airbag components, have special coatings and are specifically designed for the airbag system. They must never be replaced with any substitutes. Anytime a new fastener is needed, replace with the correct fasteners provided in the service package or fasteners listed in the parts books.

1. Turn the ignition off.
2. Disconnect and isolate the negative battery cable.
3. Wait two minutes for the system capacitor to discharge.
4. The airbag system can now be serviced safely.

Driver Side Airbag

Removal & Installation

1. Turn the ignition off.
2. Disconnect the negative battery cable.

WARNING!

Wait two minutes for the airbag system reserve capacitor to discharge before beginning any airbag system or component service. Failure to do so may result in accidental airbag development, serious or fatal injury (See Airbag System Disarming Procedure in Section 14 Restraints).

3. Remove the two driver side airbag retaining bolts (1).
(Tighten: Driver side airbag retaining bolts to 10 N·m)

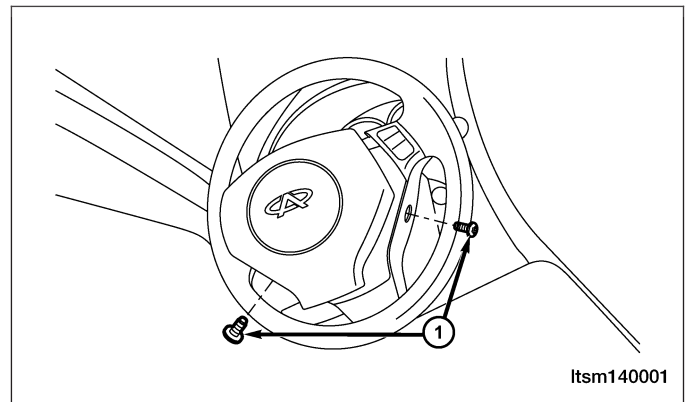

4. Remove the driver side airbag and disconnect the airbag squib electrical connector.
5. Installation is in the reverse order of removal.

Front Passenger Side Airbag

Removal & Installation

1. Turn the ignition off.
2. Disconnect the negative battery cable.

WARNING!

Wait two minutes for the airbag system reserve capacitor to discharge before beginning any airbag system or component service. Failure to do so may result in accidental airbag development, serious or fatal injury (See Airbag System Disarming Procedure in Section 14 Restraints).

3. Remove the two glove box mounting bolts (1).

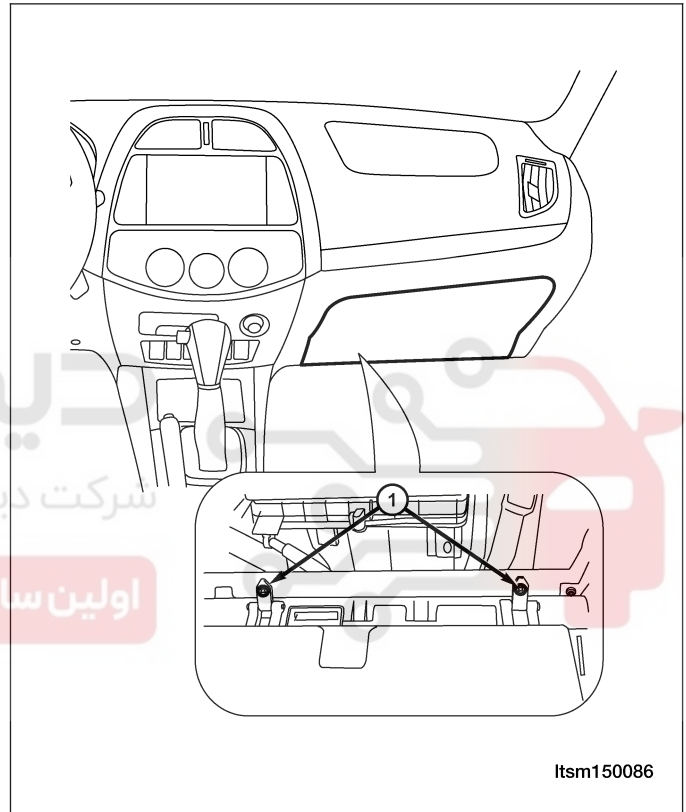

دیجیتال خودرو
شرکت دیجیتال خودرو سامانه (مسئولیت محدود)
اولین سامانه دیجیتال تعمیرکاران خودرو در ایران

ON-VEHICLE SERVICE

4. Remove the front passenger side airbag mounting bolts (1).
(Tighten: Front passenger side airbag mounting bolts to 10 N·m)

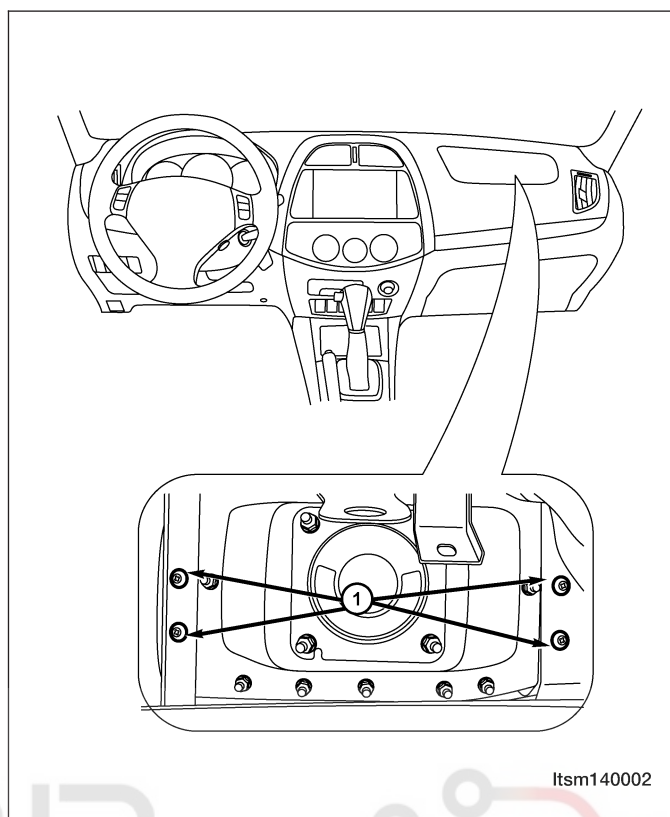

5. Disconnect the front passenger side airbag squib electrical connector.
6. Remove the front passenger side airbag from the vehicle.
7. Installation is in the reverse order of removal.

اولین سامانه دیجیتال تعمیرکاران خودرو در ایران

Restraints Control Module (RCM)

Removal & Installation

1. Turn the ignition off.
2. Disconnect the negative battery cable.

WARNING!

Wait two minutes for the airbag system reserve capacitor to discharge before beginning any airbag system or component service. Failure to do so may result in accidental airbag development, serious or fatal injury (See Airbag System Disarming Procedure in Section 14 Restraints).

3. Remove the center console (See Center Console Removal & Installation in Section 15 Body & Accessories).
4. Disconnect the Restraints Control Module (RCM) electrical connector (1).
5. Remove the RCM retaining bolts (2).
(Tighten: RCM retaining bolts to 7-9 N·m)

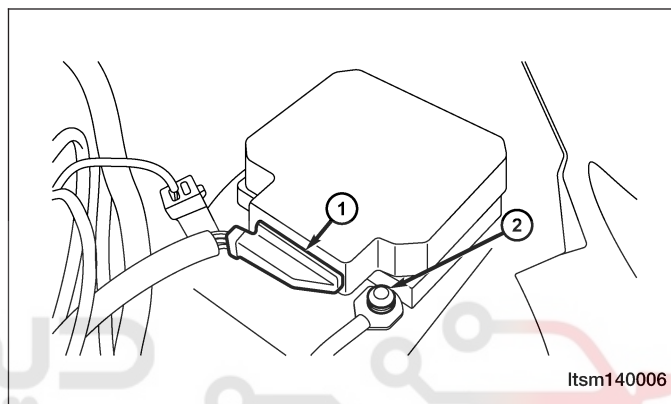

6. Remove the RCM from the vehicle.
7. Installation is in the reverse order of the removal.

اولین سامانه دیجیتال تعمیرکاران خودرو در ایران

SEAT BELT SYSTEM

GENERAL INFORMATION

Description	14-51	Seat Belt Slider Track	14-53
Operation	14-51	Removal & Installation	14-53
Specifications	14-51	Rear Seat Belt and Pre-Tensioner	14-54
Special Tools	14-51	Removal & Installation	14-54

ON-VEHICLE SERVICE

Front Seat Belt and Pre-Tensioner	14-52
Removal & Installation	14-52

دیجیتال خودرو

شرکت دیجیتال خودرو سامانه (مسئولیت محدود)

اولین سامانه دیجیتال تعمیرکاران خودرو در ایران



GENERAL INFORMATION

Description

The left and right seat belt buckles are bolted to the base frame of the seat. The seat belt buckles are a typical buckle design with a release button on the top to free the seat belt.

Operation

The primary passenger restraints are the seat belts. Seat belts are referred to as an active restraint because the vehicle occupants are required to physically fasten and properly adjust these restraints in order to benefit from them. The passive restraints are referred to as a supplemental restraint system because they were designed and are intended to enhance the protection for the occupants of the vehicle only when used in conjunction with the seat belts.

Specifications

Torque Specifications

DESCRIPTION	TORQUE (N·m)
Adjustable Shoulder Belt Anchor Bolts	50
Front Seat Belt Buckle Retaining Bolt	50
Front Seat Belt Pre-Tensioner Lower Retaining Bolt	50
Front Seat Belt Upper Turning Loop Retaining Bolt	50
Rear Seat Belt Pre-Tensioner Upper Retaining Bolt	50
Rear Seat Belt Pre-Tensioner Lower Retaining Bolt	50

Special Tools

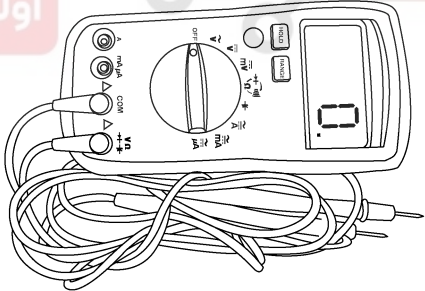
<p>اولین سامانه دیجیتال تعمیرکاران خودرو در ایران</p> <p>Digital Multimeter Fluke 15B & 17B</p>	 <p>besm030002</p>
---	--

ON-VEHICLE SERVICE

Front Seat Belt and Pre-Tensioner

Removal & Installation

1. Turn the ignition off.
2. Disconnect the negative battery cable.
3. Remove the seat belt upper mounting bolt (1).

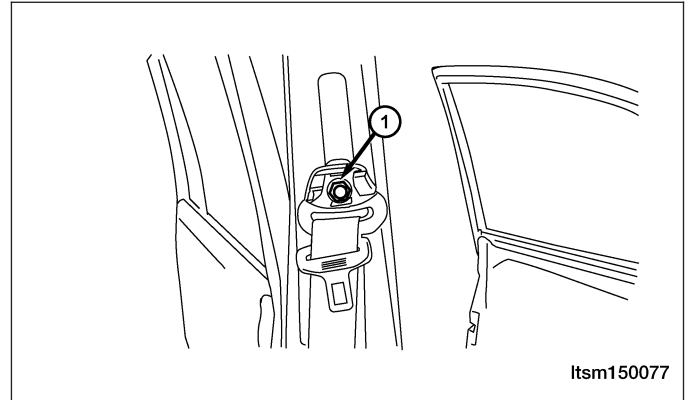

4. Remove the seat belt lower mounting bolt (1).
5. Remove the B-pillar lower trim panel.

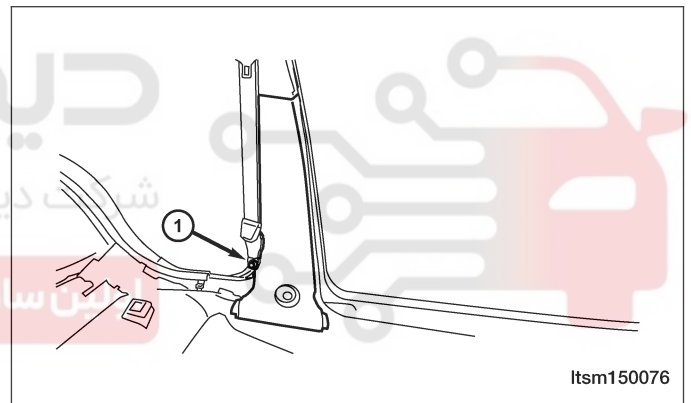

ON-VEHICLE SERVICE

6. Remove the front seat belt pre-tensioner retaining bolt (1) and screw (2).
(Tighten: Front seat belt retaining bolt to 50 N·m)

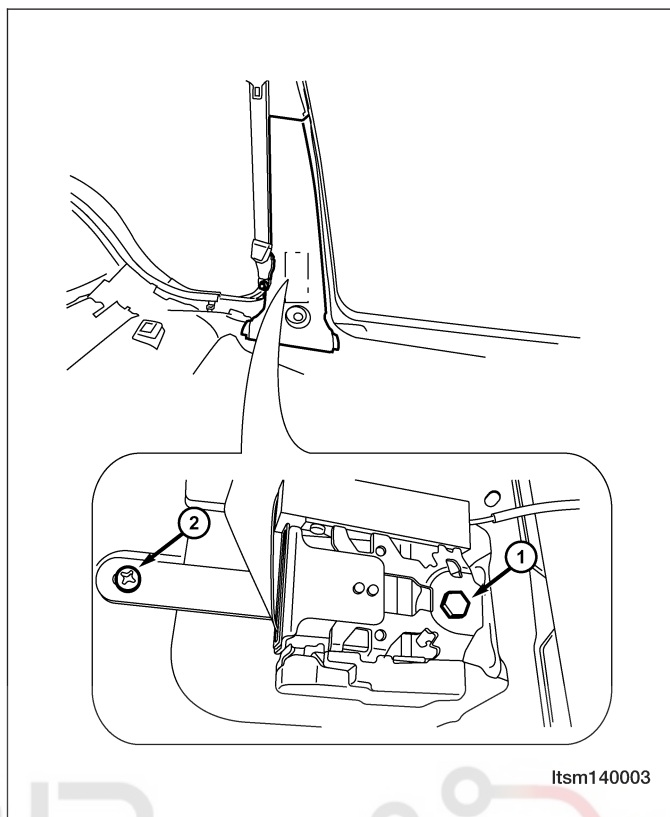

7. Remove the front seat belt and pre-tensioner.
8. Installation is in the reverse order of removal.

Seat Belt Slider Track

Removal & Installation

1. Turn the ignition off.
2. Remove the seat belt upper mounting bolt (1).

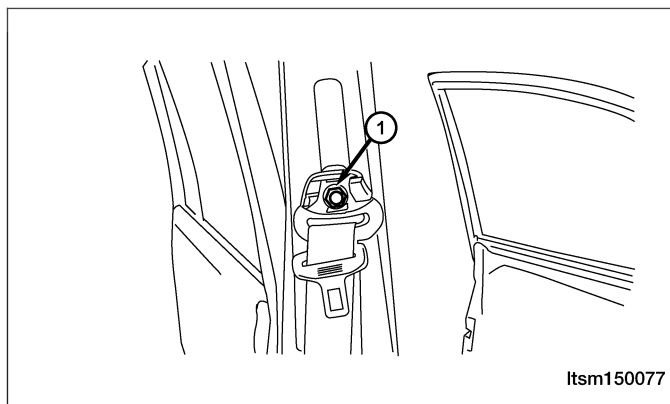

3. Remove the B-pillar upper trim panel.

ON-VEHICLE SERVICE

- Remove the two bolts (1) and then remove the seat belt slider track.
(Tighten: Adjustable shoulder belt anchor bolts to 50 N·m)

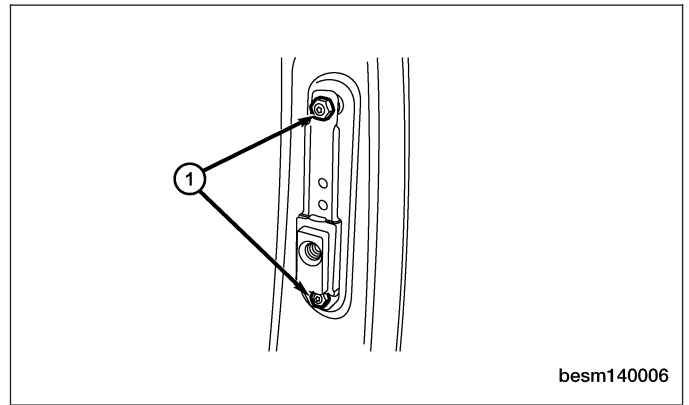

- Installation is in the reverse order of the removal.

Rear Seat Belt and Pre-Tensioner

Removal & Installation

- Turn the ignition off.
- Remove the rear seat belt mounting bolts (1).
(Tighten: Rear seat belt mounting bolts to 50 N·m)
- Remove the C-pillar (See C-pillar Trim Panel Remove & Installation in Section 15 Body & Accessories).

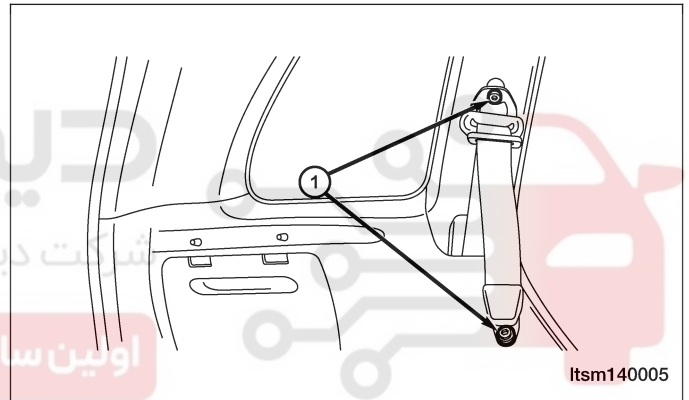

ON-VEHICLE SERVICE

4. Remove the pre-tensioner mounting bolt (1) and screw (2).

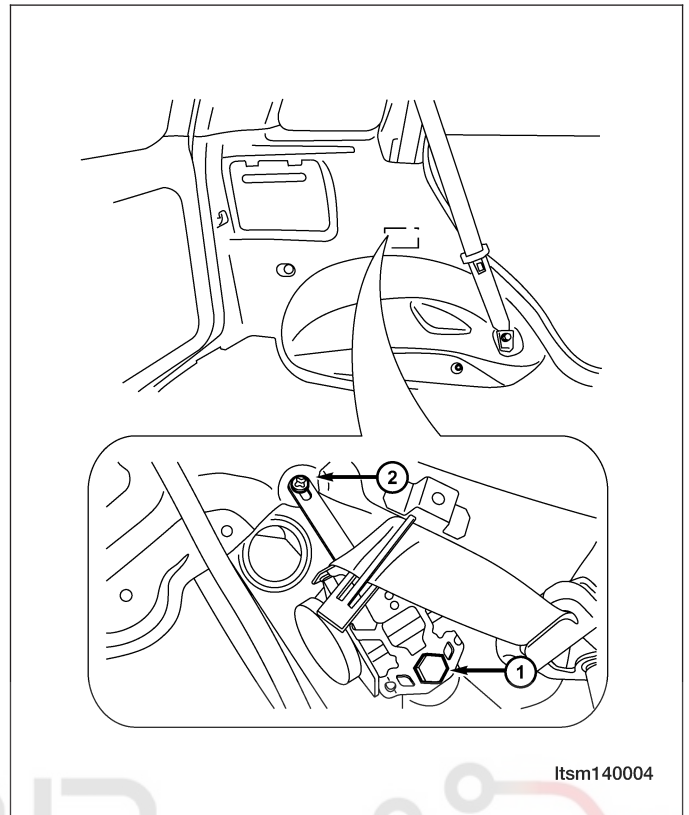

5. Remove the pre-tensioner.
6. Installation is in the reverse order of the removal.

شرکت دیجیتال خودرو (مستولیت محدود)

اولین سامانه دیجیتال تعمیرکاران خودرو در ایران