

Middle harness (D) - Instrument harness (I)

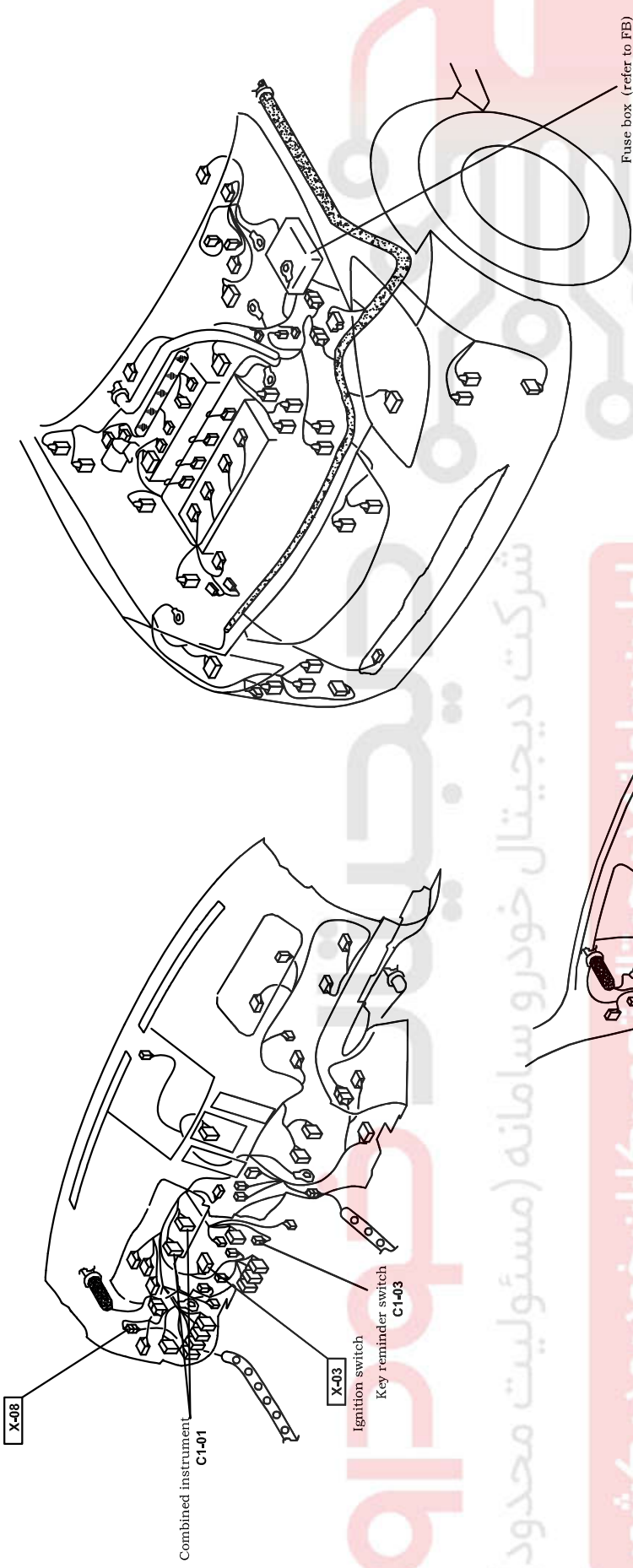

اولین سامانه دیجیتال تعمیرکاران خودرو کشور

شرکت دیجیتال خودرو سامانه (مسئولیت محدود)

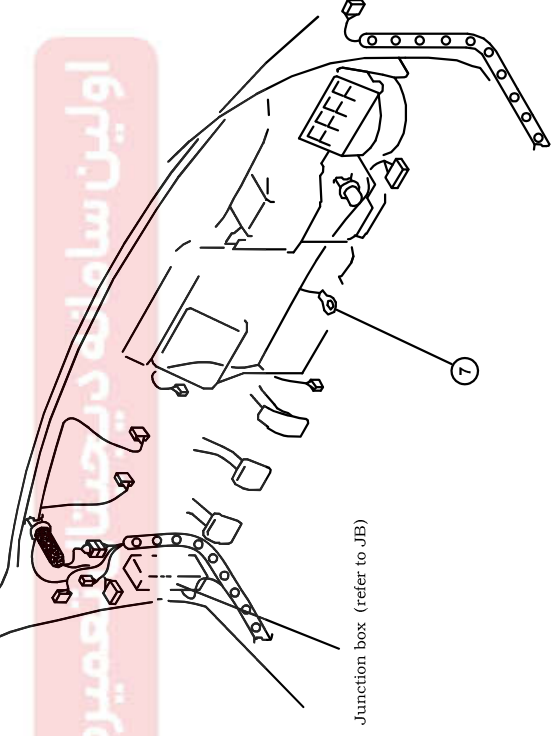

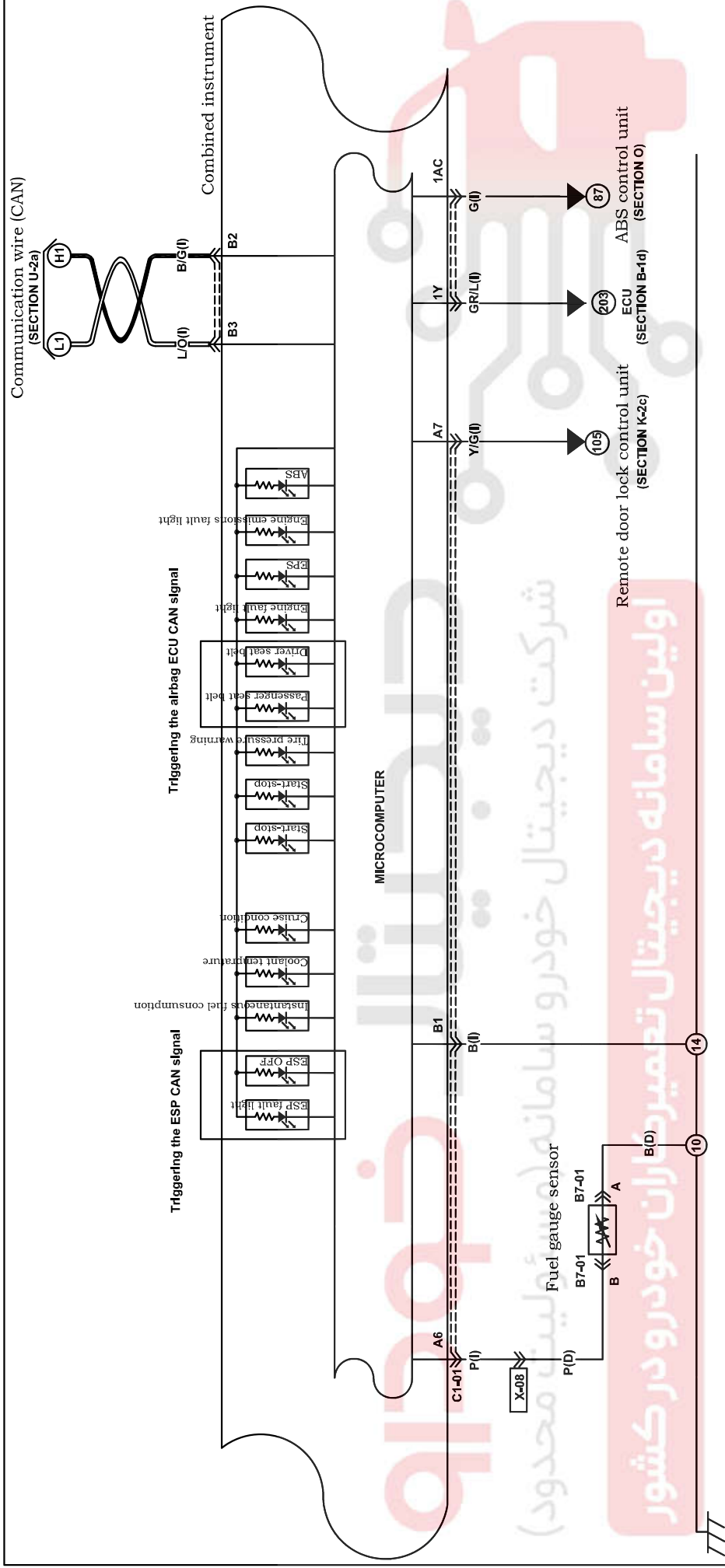

| | | | | | | | | | | | | | | | | | | | | | | | | | | | | | | | | | | | | |
|-------------------------------|--------------|-----|-----|-----|-----|-----|-----|-----|-----|------|-----|-----|-------------------------------|-----|-----|-----|------|-----|---|-----|-----|-----|--|--|-------------------------------------|--|--|--|--|--|--|--|--|--|--|--|
| C1-01 Combined instrument (I) | () with ESP | | | | | | | | | | | | C1-01 Combined instrument (I) | | | | | | | | | | | | \$ with PEPS @ with ignition switch | | | | | | | | | | | |
| | A16 | | | | A17 | | | | A32 | | | | B16 | | | | B17 | | | | B32 | | | | | | | | | | | | | | | |
| B/Y | B/L | B/W | B/R | R/Y | P | Y/G | Y/B | G/R | G/W | G/R | G/W | G/R | G/W | G/R | G/W | Y/R | BR/W | L/R | V | Y/B | Y/B | Y/B | | | | | | | | | | | | | | |
| LG | LG/B | * | * | * | * | * | * | * | G/B | LG/R | G/W | * | * | * | * | * | * | * | * | * | * | * | | | | | | | | | | | | | | |

Middle harness (D) - Instrument harness (I)

X-08

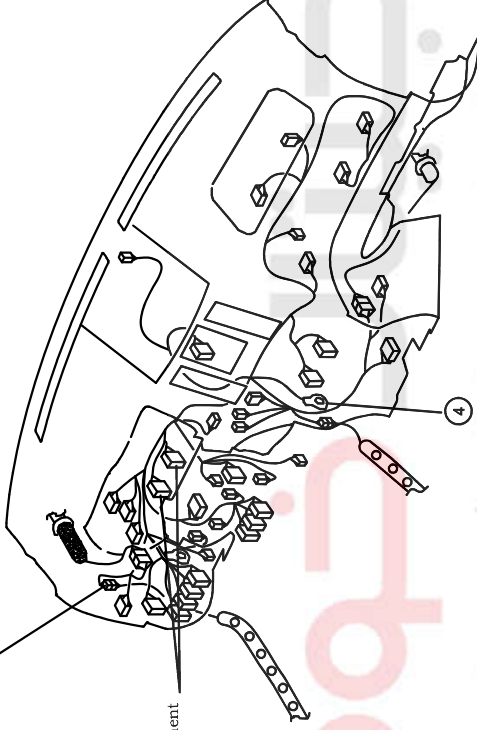

Combined instrument
C1-01

شرکت دیجیتال خودرو سامانه (مسئولیت محدود)

سامانه دیجیتال تعمیرکاران خودرو در کشور

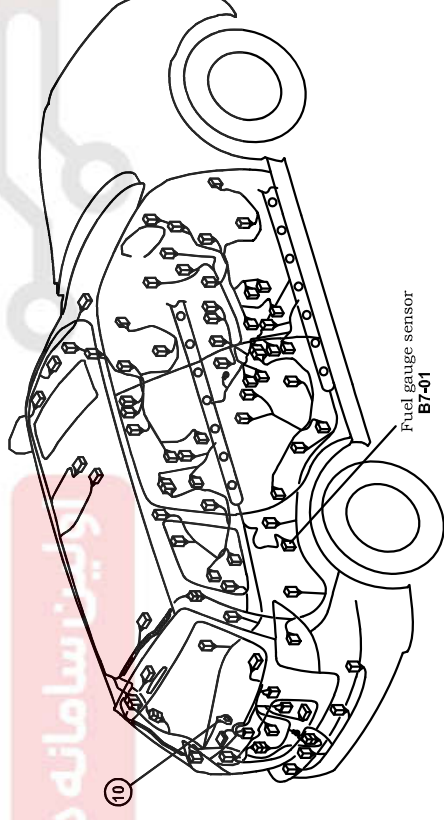

Fuel gauge sensor
B7-01

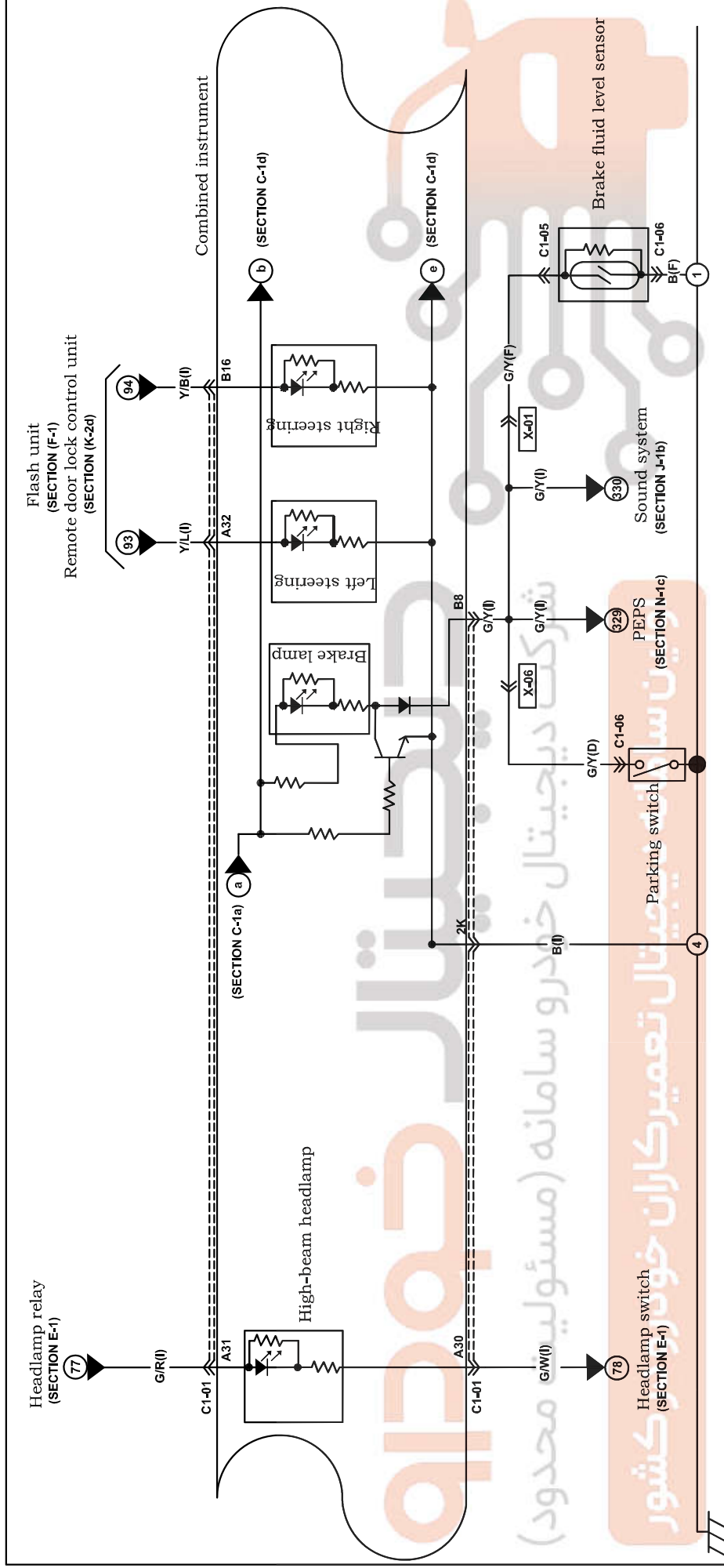

| C1-01 Combined instrument (I) | | () with ESP | | C1-01 Combined instrument (I) | | \$ with PEPS @ with ignition switch | | | | | | | | | | | |
|-------------------------------|------|--------------|-----|-------------------------------|------|-------------------------------------|--------|-------|-------|----|------|-----|------|-----|---|-----|---|
| A1 | B/Y | B/L | B/W | B/R | R/Y | P | Y/G | (G/O) | (V/W) | * | * | * | * | * | * | * | * |
| A16 | LG | LG/B | * | * | * | * | G/B | LG/R | G/W | * | * | * | * | * | * | * | * |
| A17 | | | | | | | | | | | | | | | | | |
| B1 | B | B/G | L/O | * | BR/G | \$/L/B | \$/L/W | (G/Y) | B/W | GR | GR/Y | Y/R | BR/W | L/R | V | Y/B | * |
| B17 | BR/Y | Y | @/R | @/V/W | BR/E | * | * | * | * | * | * | * | * | * | * | * | * |
| B16 | | | | | | | | | | | | | | | | | |
| B32 | | | | | | | | | | | | | | | | | |

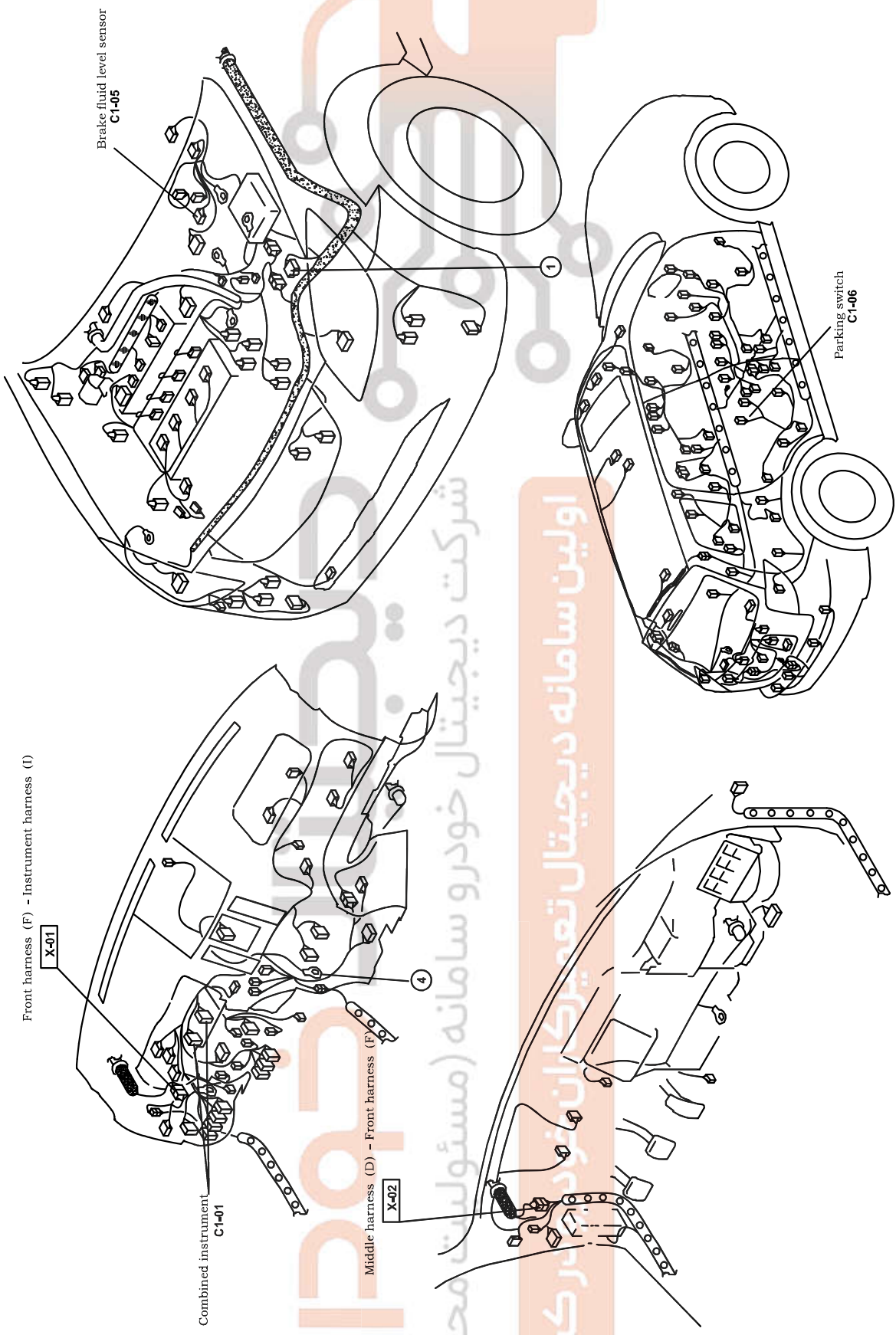

اولین سامانه دیجیتال تعمیرکاران: دفتر کشور
 شرکت دیجیتال خودرو سامانه (مسئولیت محدود)

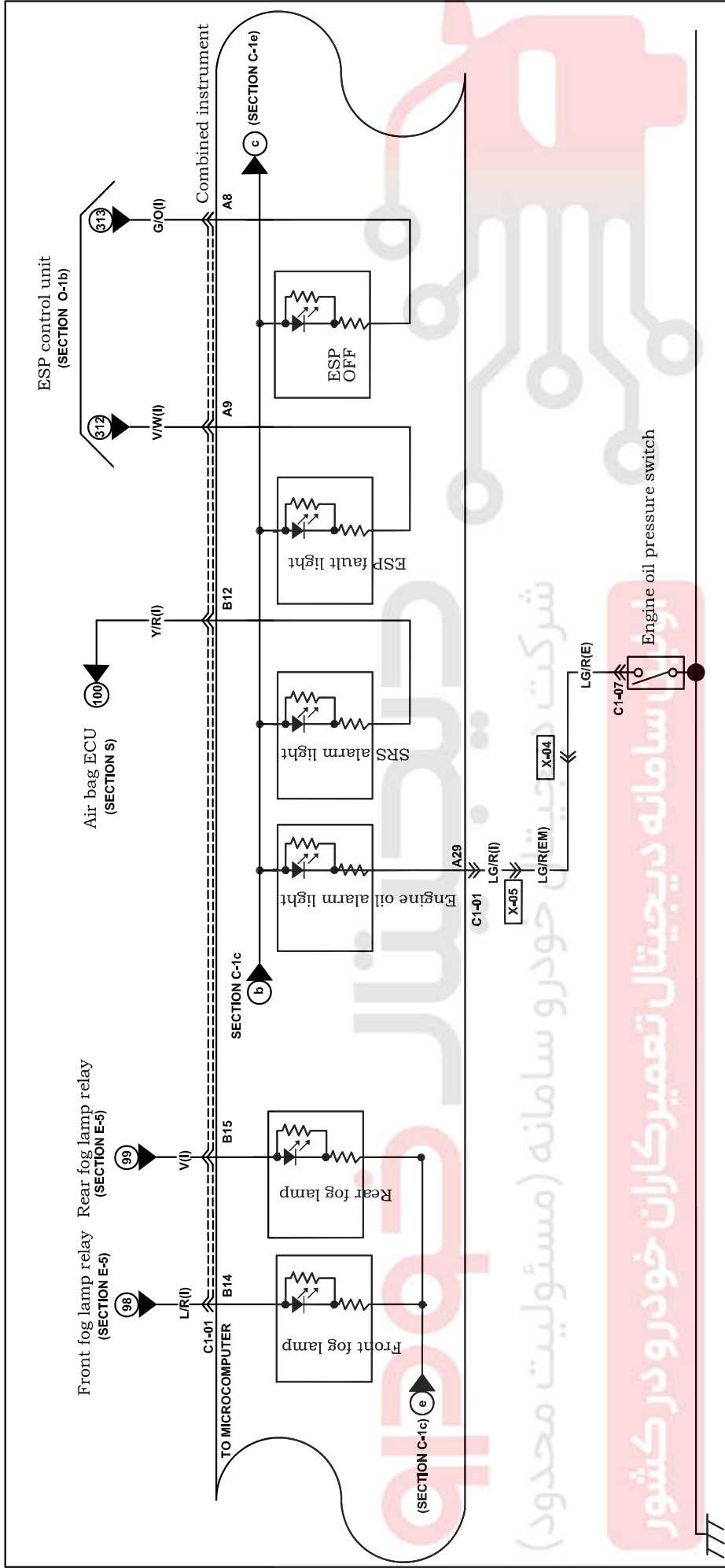

| | | | | | | | | | | | | | | | | | | | | | | | | | | | | | | | | | | | | | | | | | | | | | | | | | | | | | | | | | | | | | | | | | | | | | | | | | | | | | | | | | | | |
|-------------------------------|--|---------|-------|------|--------|--------|-------|-----|-----|------|-----|------|-----|--------------------------------------|-----|---------|-----|---|-----|-------|-------|---|---|---|---|---|----|------|---|---|---|---|-----|------|-----|-----|-----|--|--|---|--|--|--|--|--|--|--|--|--|--|--|--|---|-----|-----|---|------|--------|--------|-----|-----|----|------|-----|------|-----|---|-----|------|---|-----|-------|------|---|---|---|---|---|---|---|---|---|---|
| C1-01 Combined instrument (I) | () with ESP | | | | | | | | | | | | | C1-07 Engine oil pressure switch (E) | | | | | | | | | | | | | | | | | | | | | | | | | | | | | | | | | | | | | | | | | | | | | | | | | | | | | | | | | | | | | | | | | | | | | |
| | <p>A16</p> <table border="1"> <tr><td>B/Y</td><td>B/L</td><td>B/W/B/R</td><td>R/Y</td><td>P</td><td>Y/G</td><td>(G/O)</td><td>(V/W)</td><td>*</td><td>*</td><td>*</td><td>*</td><td>*</td></tr> <tr><td>LG</td><td>LG/B</td><td>*</td><td>*</td><td>*</td><td>*</td><td>G/B</td><td>LG/R</td><td>G/W</td><td>G/R</td><td>Y/L</td><td></td><td></td></tr> </table> <p>A17</p> | | | | | | | | | | | | | B/Y | B/L | B/W/B/R | R/Y | P | Y/G | (G/O) | (V/W) | * | * | * | * | * | LG | LG/B | * | * | * | * | G/B | LG/R | G/W | G/R | Y/L | | | <p>\$ with PEPS @ with ignition switch</p> <table border="1"> <tr><td>B</td><td>B/G</td><td>L/O</td><td>*</td><td>BR/G</td><td>\$/L/B</td><td>\$/L/W</td><td>G/Y</td><td>B/W</td><td>GR</td><td>GR/Y</td><td>Y/R</td><td>BR/W</td><td>L/R</td><td>V</td><td>Y/B</td></tr> <tr><td>BR/Y</td><td>Y</td><td>@/R</td><td>@/V/W</td><td>BR/E</td><td>*</td><td>*</td><td>*</td><td>*</td><td>*</td><td>*</td><td>*</td><td>*</td><td>*</td><td>*</td><td>*</td></tr> </table> <p>B32</p> | | | | | | | | | | | | | B | B/G | L/O | * | BR/G | \$/L/B | \$/L/W | G/Y | B/W | GR | GR/Y | Y/R | BR/W | L/R | V | Y/B | BR/Y | Y | @/R | @/V/W | BR/E | * | * | * | * | * | * | * | * | * | * |
| B/Y | B/L | B/W/B/R | R/Y | P | Y/G | (G/O) | (V/W) | * | * | * | * | * | | | | | | | | | | | | | | | | | | | | | | | | | | | | | | | | | | | | | | | | | | | | | | | | | | | | | | | | | | | | | | | | | | | | | | | |
| LG | LG/B | * | * | * | * | G/B | LG/R | G/W | G/R | Y/L | | | | | | | | | | | | | | | | | | | | | | | | | | | | | | | | | | | | | | | | | | | | | | | | | | | | | | | | | | | | | | | | | | | | | | | | | |
| B | B/G | L/O | * | BR/G | \$/L/B | \$/L/W | G/Y | B/W | GR | GR/Y | Y/R | BR/W | L/R | V | Y/B | | | | | | | | | | | | | | | | | | | | | | | | | | | | | | | | | | | | | | | | | | | | | | | | | | | | | | | | | | | | | | | | | | | | |
| BR/Y | Y | @/R | @/V/W | BR/E | * | * | * | * | * | * | * | * | * | * | * | | | | | | | | | | | | | | | | | | | | | | | | | | | | | | | | | | | | | | | | | | | | | | | | | | | | | | | | | | | | | | | | | | | | |

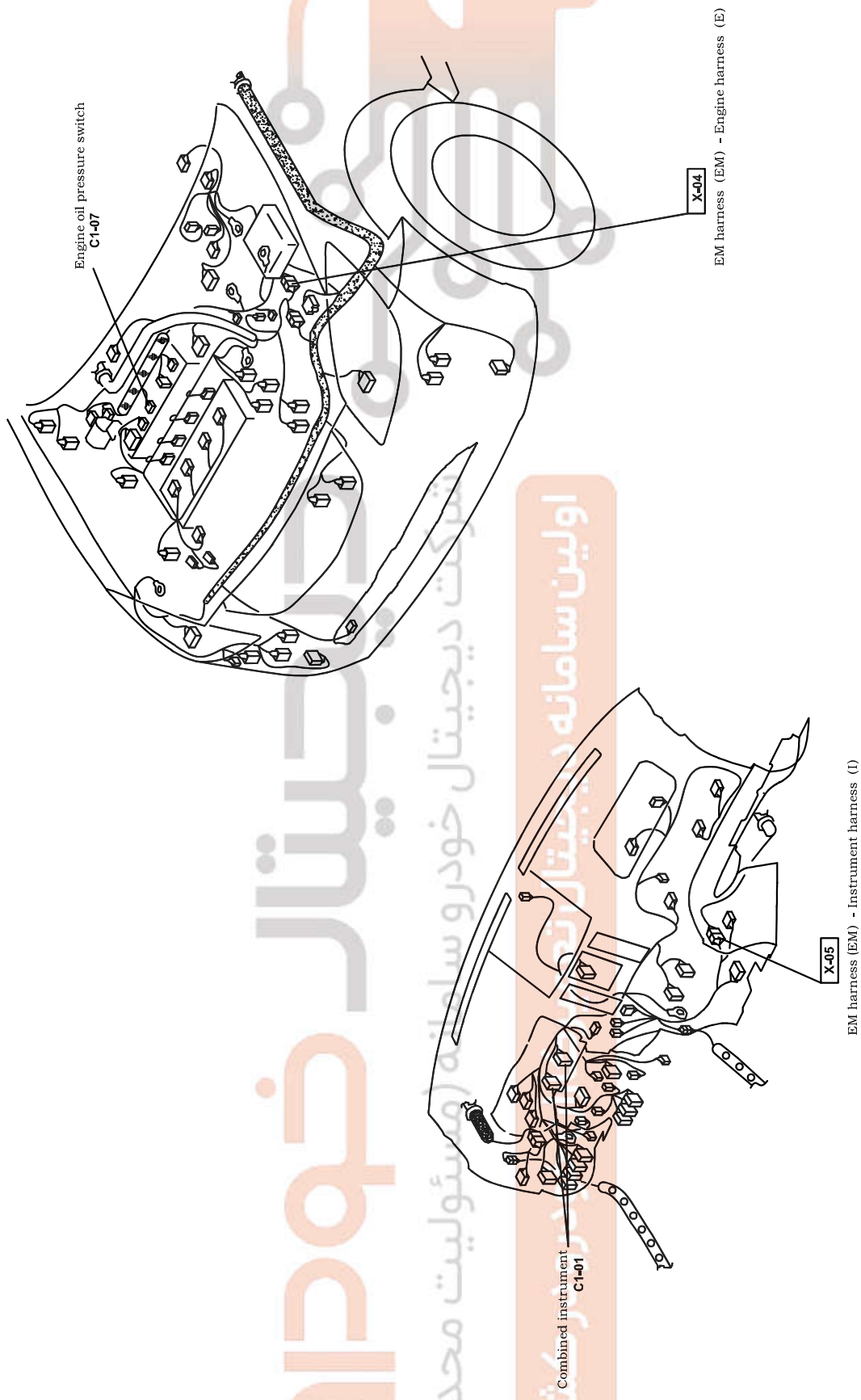

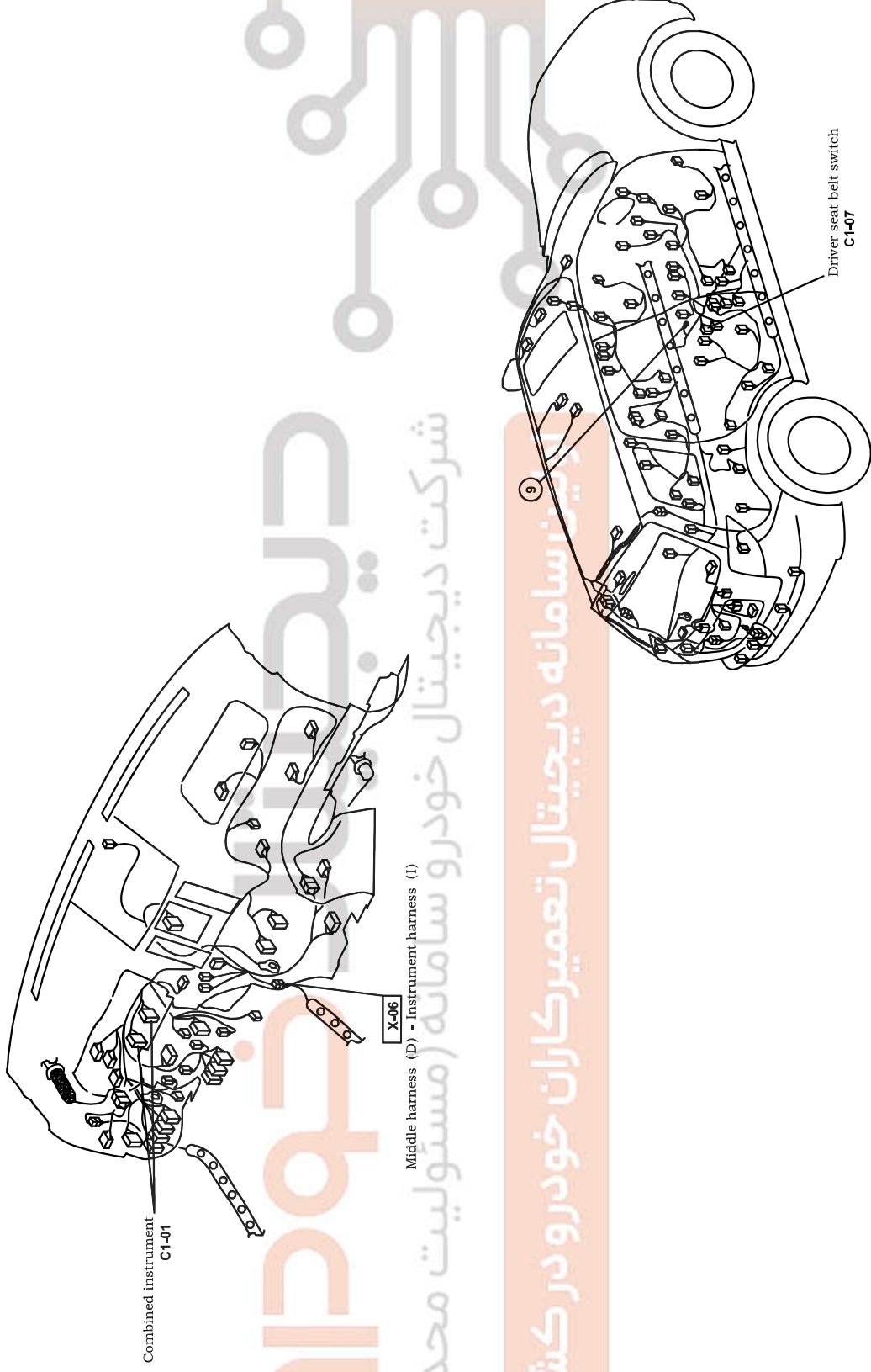

شرکت دیجیتال خودرو سامانه (مسئولیت محدود)

سامانه دیجیتال تعمیرکاران خودرو در کشور

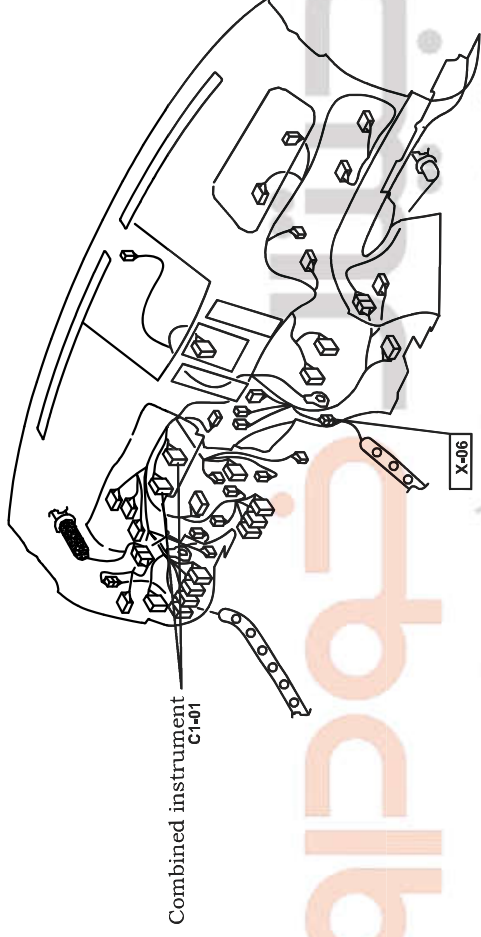

Middle harness (D) -Instrument harness (I)

شرکت دیجیتال خودرو (مسئولیت محدود)

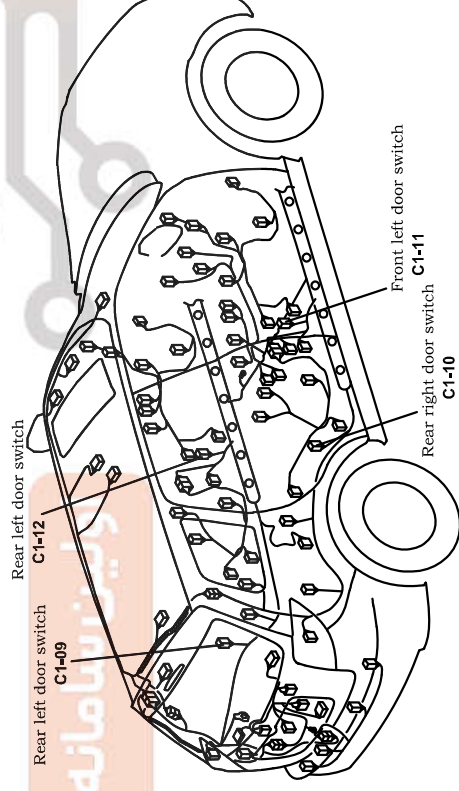

Rear left door switch C1-09

Rear left door switch C1-12

Front left door switch C1-11

Rear right door switch C1-10

تعمیرکاران خودرو در کشور