

# CAN System

## Circuit Diagram (Page 1 of 2)

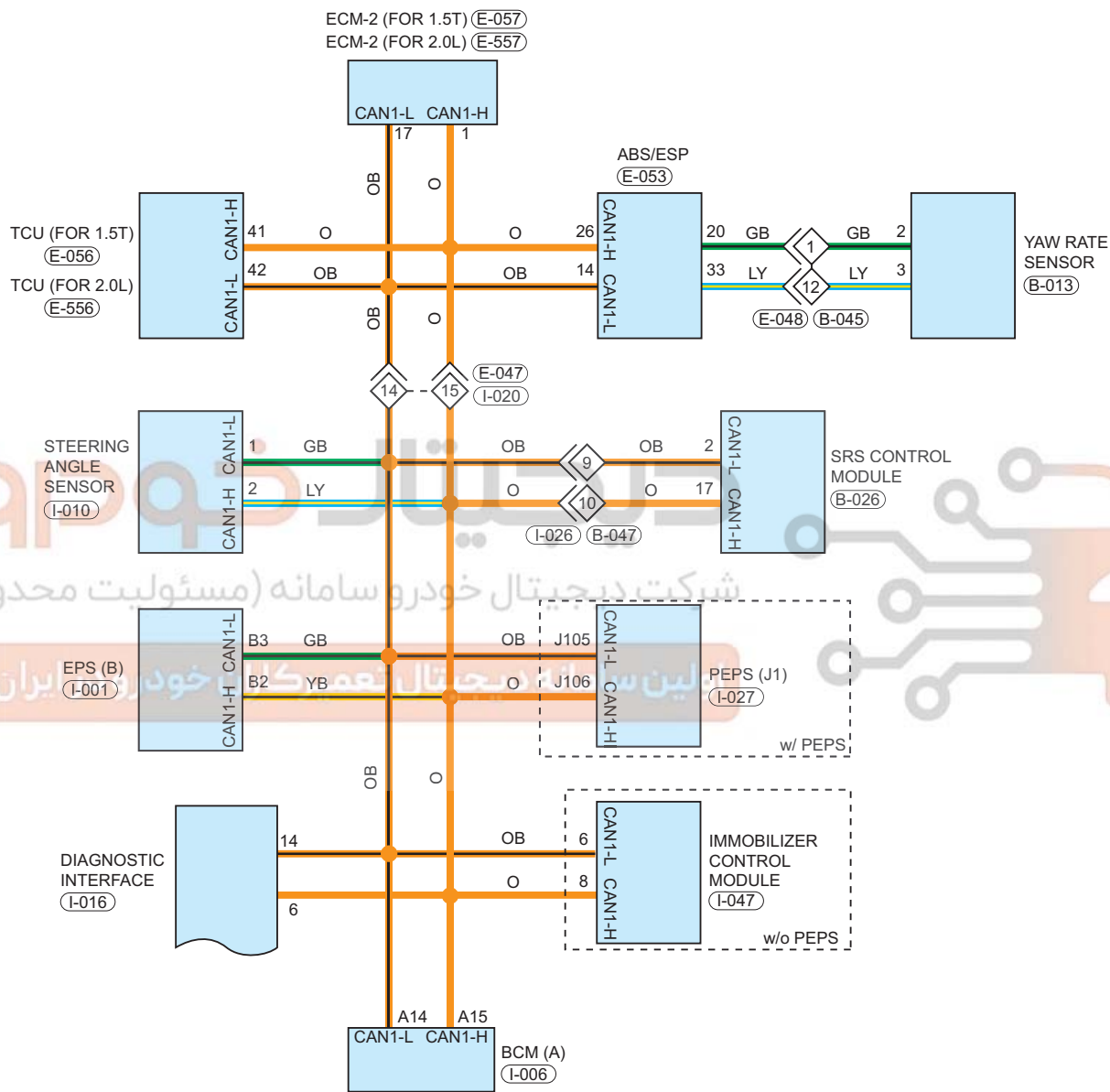

## 09 - SYSTEM CIRCUITS

## Parts Location

Connector Code	See Page	Connector Code	See Page	Connector Code	See Page
E-056	08-7	E-057	08-7	E-053	08-7
B-013	08-16	I-010	08-13	B-026	08-19
I-001	08-13	I-016	08-13	I-027	08-13
I-047	08-13	I-006	08-13	E-556	08-10
E-557	08-10				

## Location of Junction Connector

Connector Code	See Page	Connector Code	See Page	Connector Code	See Page
E-048, B-045	08-7, 08-19	E-047, I-020	08-7, 08-13	I-026, B-047	08-13, 08-19

## Form of Connector

Connector Code	See Page	Connector Code	See Page	Connector Code	See Page
E-056	12-4	E-057	12-4	E-053	12-4
B-013	12-11	I-010	12-9	B-026	12-12
I-001	12-9	I-016	12-9	I-027	12-10
I-047	12-10	I-006	12-9	E-556	12-7
E-557	12-7	I-026, B-047	12-10	E-047, I-020	12-3
E-048, B-045	12-3				

Circuit Diagram (Page 2 of 2)

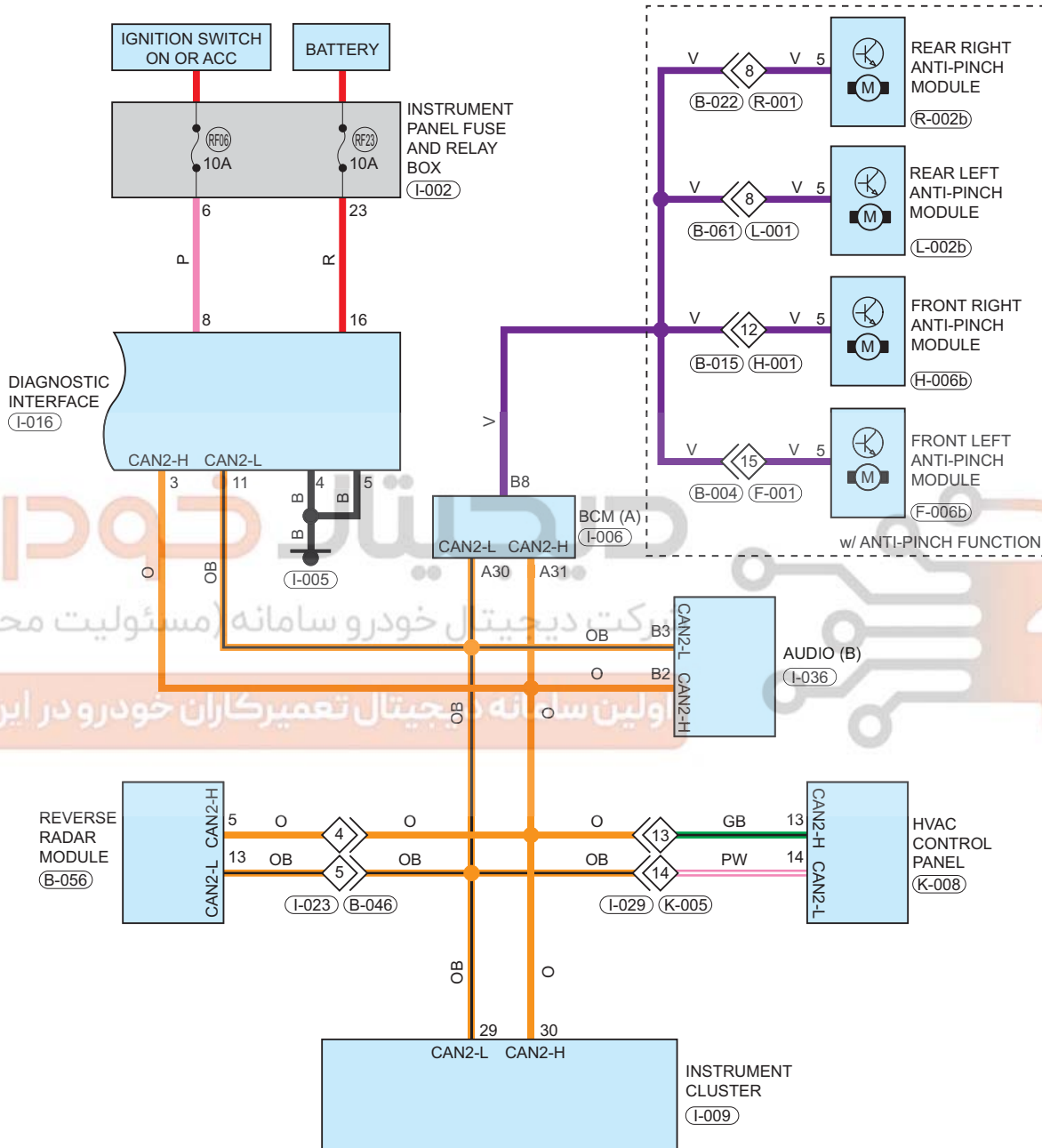

ET21091320