

STARTING & CHARGING

05

CONTENTS

	page
Starting System	05-1
Charging System	05-11

STARTING SYSTEM

GENERAL INFORMATION	05-2	Positive Battery Cable	05-8
Description	05-2	Removal & Installation	05-8
Operation	05-3	Negative Battery Cable	05-8
Specifications	05-3	Removal & Installation	05-8
Special Tools	05-3	Battery Hold Down	05-8
Electrical Schematics	05-4	Removal & Installation	05-8
DIAGNOSIS AND TESTING	05-6	Battery Tray	05-9
Starter Motor Bench Test	05-6	Removal & Installation	05-9
Starter Solenoid Test	05-6	Starter Motor Assembly	05-9
ON-VEHICLE SERVICE	05-7	Description	05-9
Battery	05-7	Operation	05-9
Description	05-7	Removal & Installation - 1.6L & 1.8L & 2.0L	05-9
Operation	05-7	Removal & Installation - 2.4L	05-10
Removal & Installation	05-7		

GENERAL INFORMATION

Description

1.6L & 1.8L & 2.0L

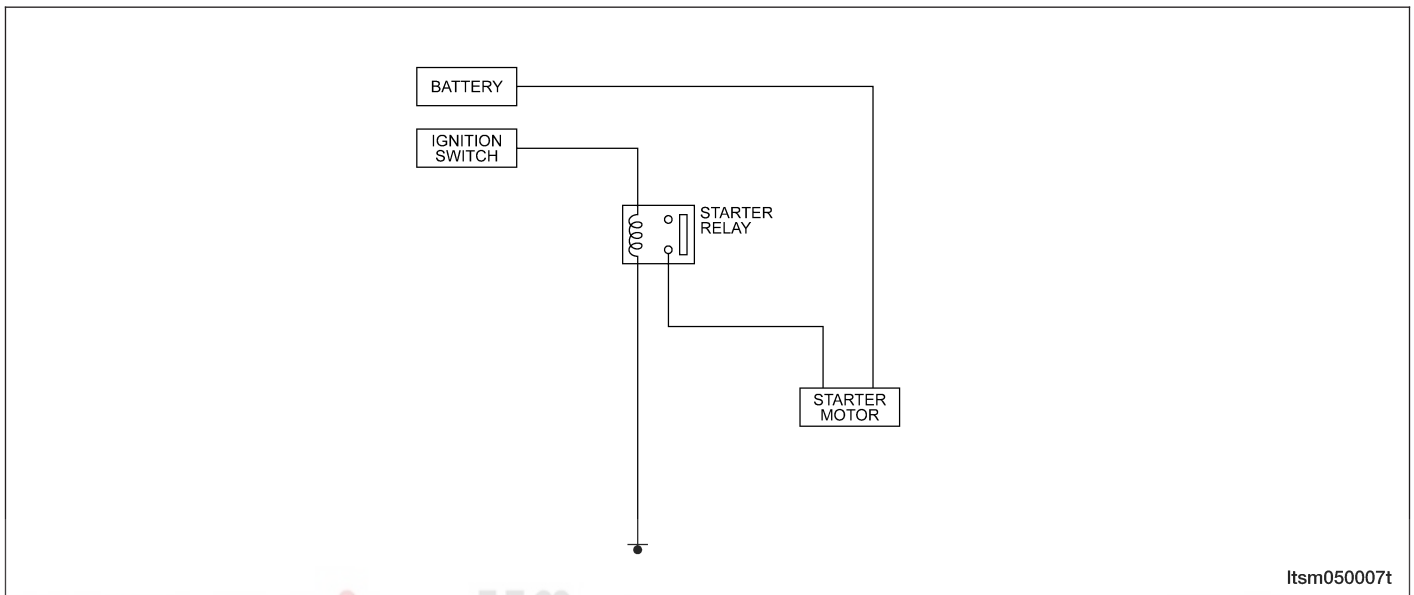

2.4L

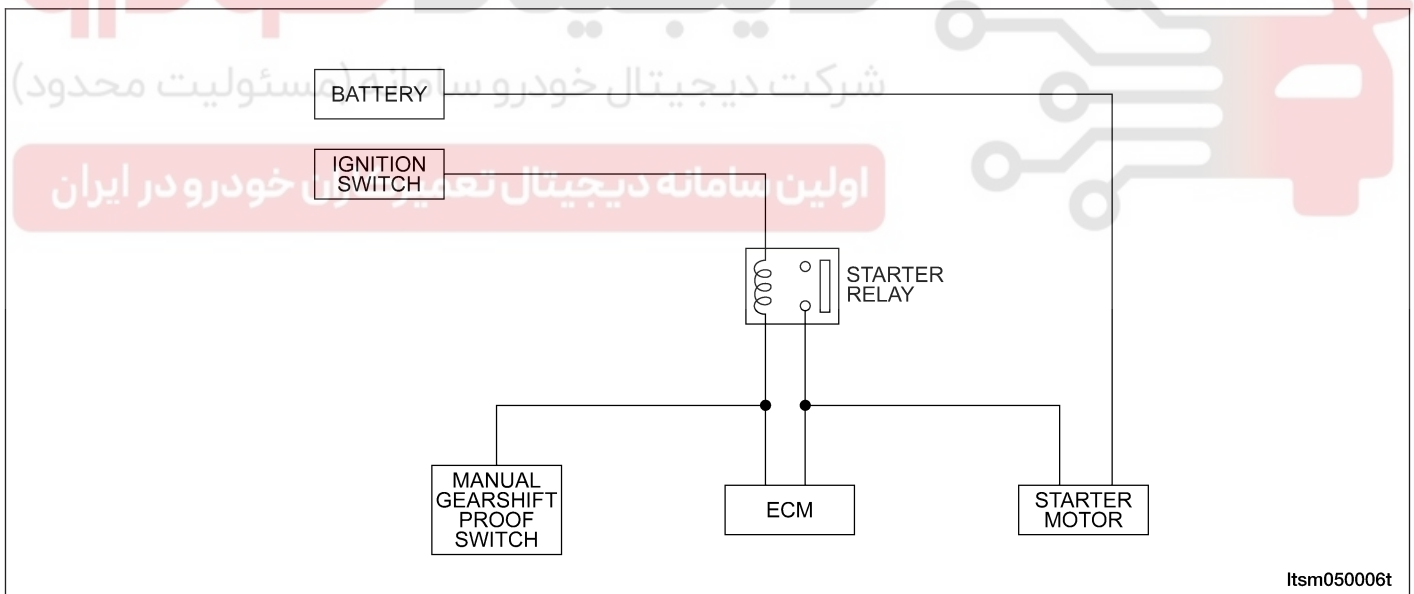

The starting system consists of the following components:

- Starter motor (including an integral starter solenoid)
- Battery
- Battery cables
- Ignition switch and key lock cylinder
- Wire harnesses and connections
- Starter relay and fuse
- Charge fuse

GENERAL INFORMATION

Operation

The battery, starting and charging systems operate in conjunction with one another, and must be tested as a complete system. For correct operation of starting/charging systems, all components used in these 3 systems must perform within specifications. When attempting to diagnose any of these systems, it is important that you keep their interdependency in mind. These components form two separate circuits, a high amperage circuit that feeds the starter motor up to 150 amps, and a control circuit that operates on less than 20 amps.

Specifications

Torque Specifications

DESCRIPTION	TORQUE (N·m)
Starter Mounting Bolts	30
Battery Positive Cable Nut	15

05

Special Tools



اولین سامانه دیجیتال تعمیرکاران خودرو در ایران

GENERAL INFORMATION

Electrical Schematics

Starting System (Page 1 of 2)

STARTING SYSTEM - WITH MITSUBISHI ENGINE SYSTEM AND WITH A/T

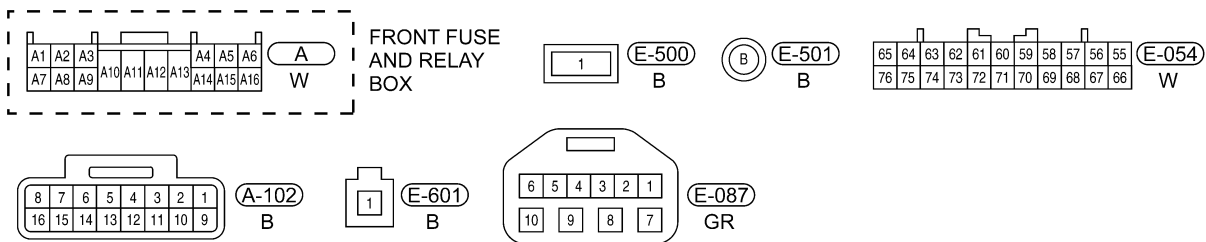
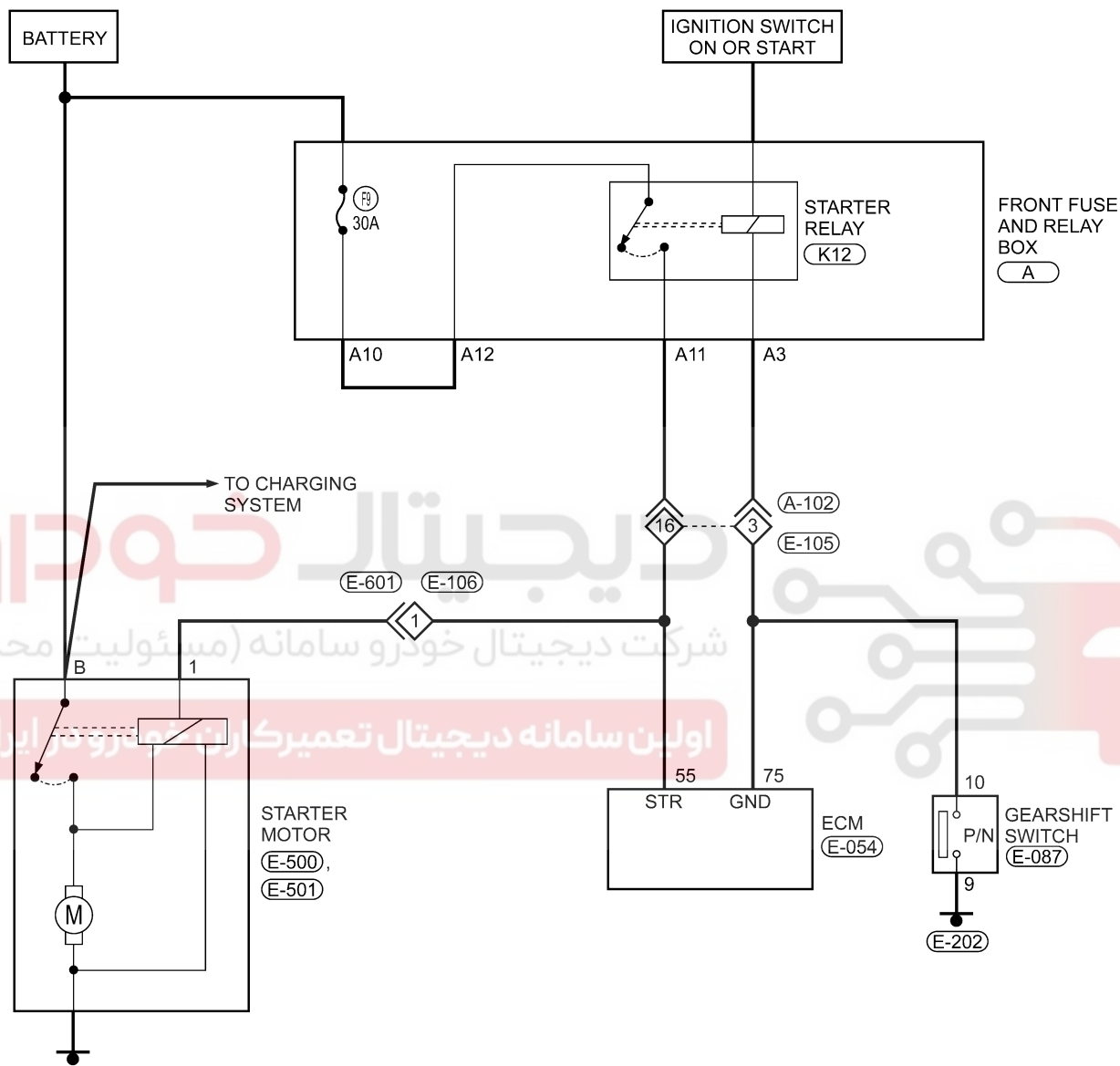

GENERAL INFORMATION

Starting System (Page 2 of 2)

STARTING SYSTEM - WITH ACTECO ENGINE SYSTEM

- A1 : WITH ACTECO 1.6 - 1.8L ENGINE
- A2 : WITH ACTECO 2.0L ENGINE
- AT : WITH AUTO TRANSMISSION

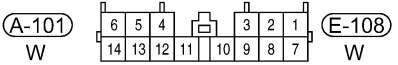
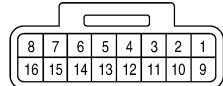
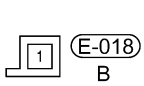
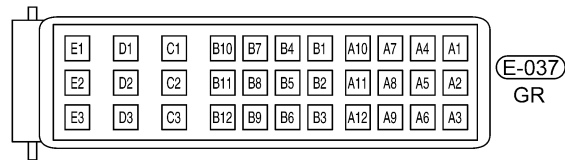
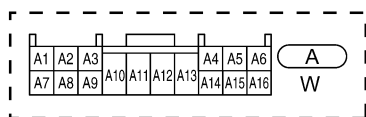
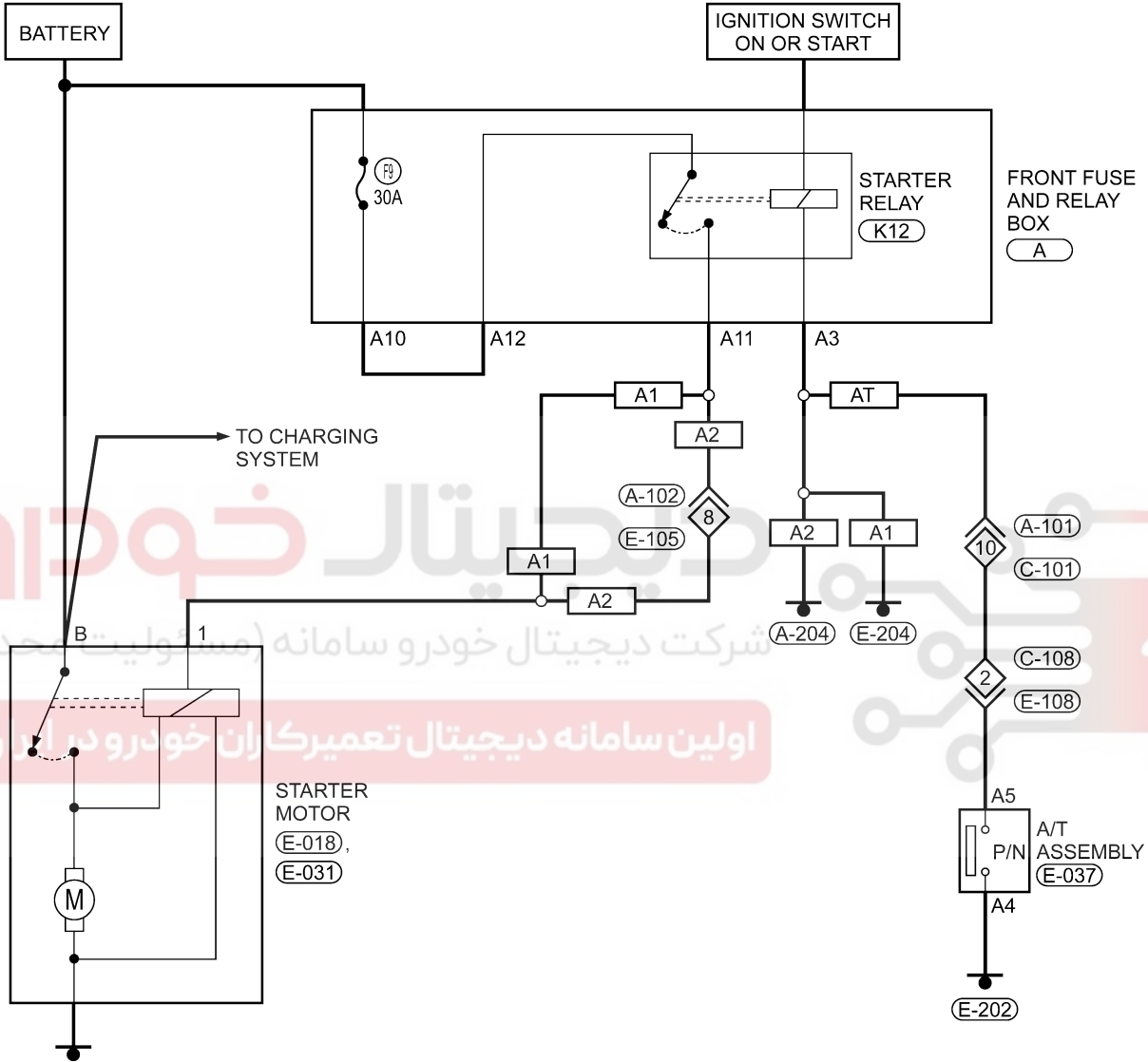

05

ltsmw050003t

DIAGNOSIS AND TESTING

Starter Motor Bench Test

Starter motor operation can be confirmed by performing the following free-running bench test. This test can only be performed with the starter motor removed from the vehicle.

1. Remove the starter motor from the vehicle (See Starter Motor Removal & Installation in Section 05 Starting and Charging).
2. Mount the starter motor securely in a soft-jawed bench vise. The vise jaws should be clamped on the mounting flange of the starter motor (never clamp on the starter motor by the field frame).
3. Connect a suitable volt-ampere tester and a 12 V battery to the starter motor in series, and set the ammeter to the 100 A scale.
4. Install a jumper wire from the solenoid terminal to the solenoid battery terminal. The starter motor should operate. If the starter motor fails to operate, replace the faulty starter motor assembly.
5. Adjust the carbon pile load of the tester to obtain the free running test voltage.
6. Note the reading on the ammeter and compare this reading to the free-running test maximum amperage draw.
7. If the ammeter reading exceeds the maximum amperage draw specification, replace the faulty starter motor assembly.

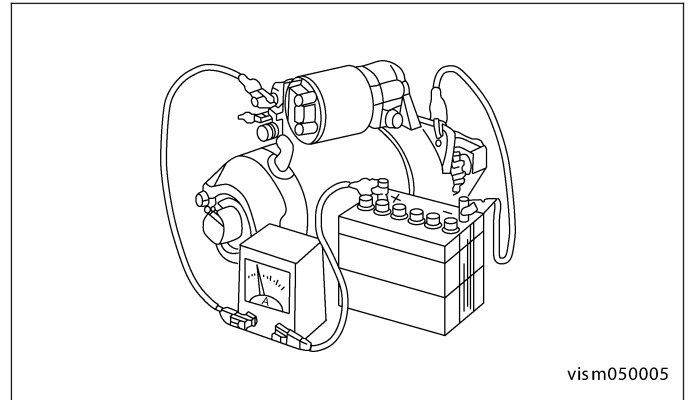

Starter Solenoid Test

This test can only be performed with the starter motor removed from the vehicle.

1. Remove the starter motor from the vehicle (See Starter Motor Removal & Installation in Section 05 Starting and Charging).
2. Disconnect the wire from the solenoid field coil terminal.
3. Check the solenoid for continuity between the solenoid terminal and the solenoid field coil terminal with a continuity tester. There should be continuity. If there is continuity, go to Step 4. If not, replace the faulty starter motor assembly.
4. Using a continuity tester, check for continuity between the solenoid terminal and the solenoid case. There should be continuity. If not, replace the faulty starter motor assembly.

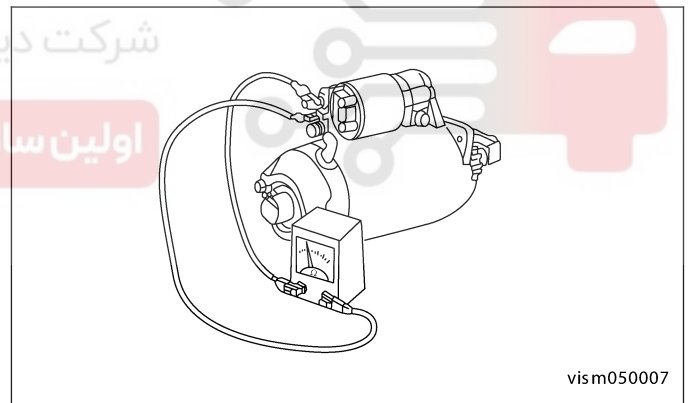

ON-VEHICLE SERVICE

Battery

Description

This vehicle is equipped with a single 12 V battery. All of the components of the battery system are located within the engine compartment of the vehicle. The battery system for this vehicle contains the following components:

- Battery - The storage battery provides a reliable means of storing a renewable source of electrical energy within the vehicle.
- Battery Cables - The battery cables connect the positive and negative charged battery terminal posts to the vehicle electrical system.
- Battery Hold Down - The battery hold down hardware secures the battery in the battery tray.
- Battery Tray - The battery tray provides a secure mounting location in the vehicle for the battery and an anchor point for the battery hold down hardware.

Operation

The battery is designed to store electrical energy in a chemical form. When an electrical load is applied to the terminals of the battery, an electrochemical reaction occurs. This reaction causes the battery to discharge electrical current from its terminals. As the battery discharges, a gradual chemical change takes place within each cell. The sulfuric acid in the electrolyte combines with the plate materials, causing both plates to slowly change to lead sulfate. At the same time, oxygen from the positive plate material combines with hydrogen from the sulfuric acid, causing the electrolyte to become mainly water. The chemical changes within the battery are caused by the movement of excess or free electrons between the positive and negative plate groups. This movement of electrons produces a flow of electrical current through the load device attached to the battery terminals.

Removal & Installation

1. Disconnect the negative battery cable.
2. Disconnect the positive battery cable.
3. Remove the battery hold down retaining nuts (1).

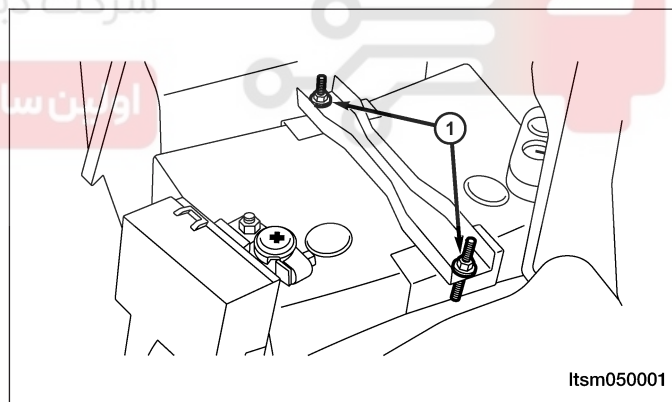

Itsm050001

4. Remove the battery.
5. Installation is in the reverse order of removal.

Positive Battery Cable

Removal & Installation

1. Disconnect the negative battery cable.
2. Disconnect the positive battery cable.
3. Remove the battery cable from the B+ terminal of the generator.
4. Remove the battery cable from the B+ terminal of the starter motor.
5. One at a time, trace the battery cable retaining push pins, fasteners and routing clamps until the cables are free from the vehicle.
6. Remove the battery cable from the engine compartment.
7. Installation is in the reverse order of removal.

Negative Battery Cable

Removal & Installation

1. Disconnect the negative battery cable.
2. Remove the bolts securing the negative cable to the body ground and the transaxle.
3. One at a time, trace the battery cable retaining push pins, fasteners and routing clamps until the cables are free from the vehicle.
4. Remove the battery cable from the engine compartment.
5. Installation is in the reverse order of removal.

Battery Hold Down

Removal & Installation

1. Remove the retaining nuts (1).

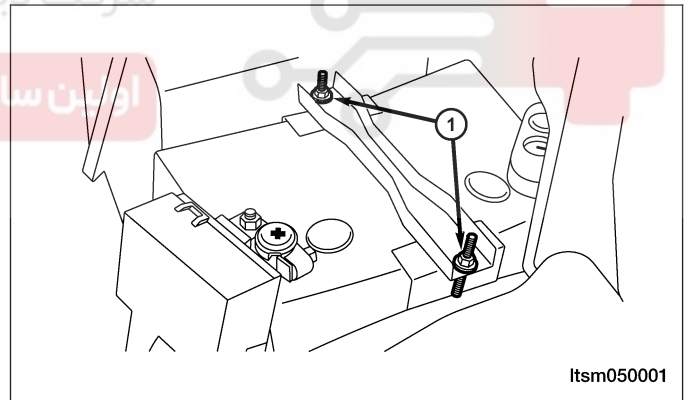

2. Remove the battery hold down.
3. Installation is in the reverse order of removal.

Battery Tray

Removal & Installation

1. Disconnect the negative battery cable.
2. Disconnect the positive battery cable.
3. Remove the battery hold down.
4. Remove the battery.
5. Remove the three bolts (1) from the battery tray.
6. Lift the battery tray out of the engine compartment and remove from the vehicle.
7. Installation is in the reverse order of removal.

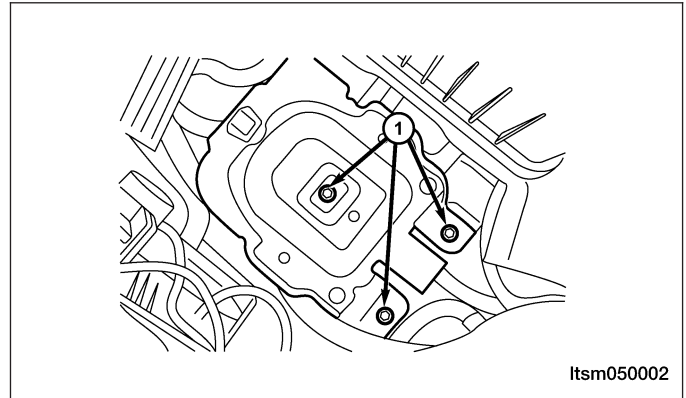

05

Starter Motor Assembly

Description

The starter motor is mounted with two bolts to the transaxle housing and is located on the side of the engine. The starter motor incorporates several features to create a reliable, efficient, compact, lightweight and powerful unit. The electric motor of the starter features electromagnetic field coils wound around pole shoes, and brushes contact the motor commutator. The starter motor is serviced only as a unit and cannot be repaired.

Operation

The starter motor is equipped with a planetary gear reduction system. The planetary gear reduction system consists of a gear that is integral to the output end of the electric motor armature shaft that is in continual engagement with a larger gear that is splined to the input end of the starter pinion gear shaft. This feature makes it possible to reduce the dimensions of the starter. At the same time, it allows higher armature rotational speed and delivers increased torque through the starter pinion gear to the starter ring gear.

Removal & Installation - 1.6L & 1.8L & 2.0L

1. Disconnect the negative battery cable.
2. Disconnect the electrical connector from the starter.
3. Remove the bolts connecting the engine oil dipstick to the cylinder block and intake manifold.
4. Remove the engine oil dipstick.

NOTE :

After removing the engine oil dipstick, you should immediately plug the hole in the cylinder block in order to prevent any debris from entering the engine.

5. Remove the starter solenoid nut (1) from the starter.
(Tighten: Starter solenoid nut to 10 N·m)

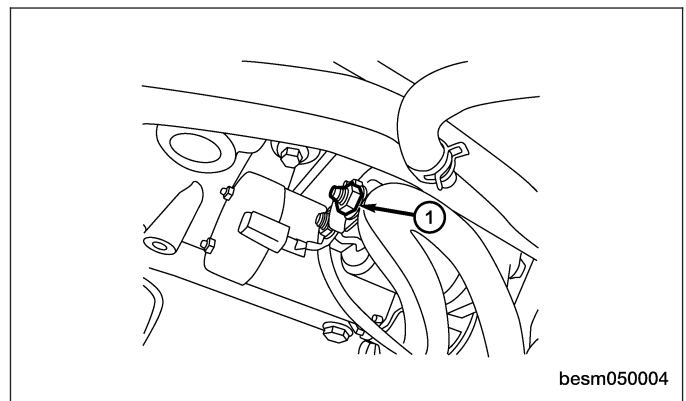

ON-VEHICLE SERVICE

6. Remove the two starter mounting bolts (1) connecting the starter and transaxle.
(Tighten: Starter mounting bolts to 30 N·m)
7. Remove the starter from the engine.
8. Installation is in the reverse order of removal.

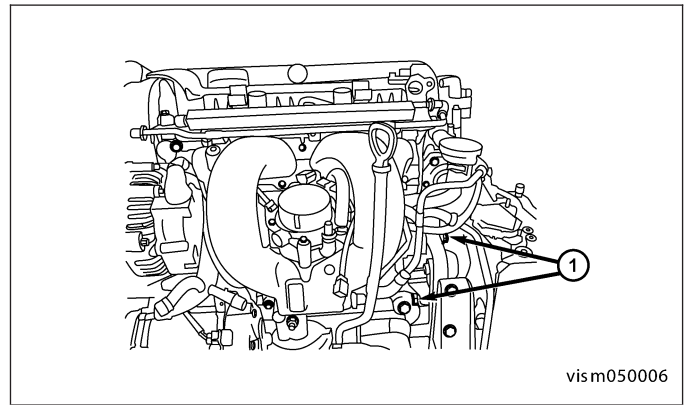

Removal & Installation - 2.4L

1. Disconnect the negative battery cable.
2. Remove the exhaust manifold (See Exhaust Manifold Removal & Installation in Section 02 Engine).
3. Disconnect the electrical connector from the starter.
4. Remove the starter solenoid nuts from the starter.
(Tighten: Starter solenoid nuts to 10 N·m)
5. Remove the two starter mounting bolts (1) connecting the starter and transaxle.
(Tighten: Starter mounting bolts to 30 N·m)
6. Remove the starter from the engine.
7. Installation is in the reverse order of removal.

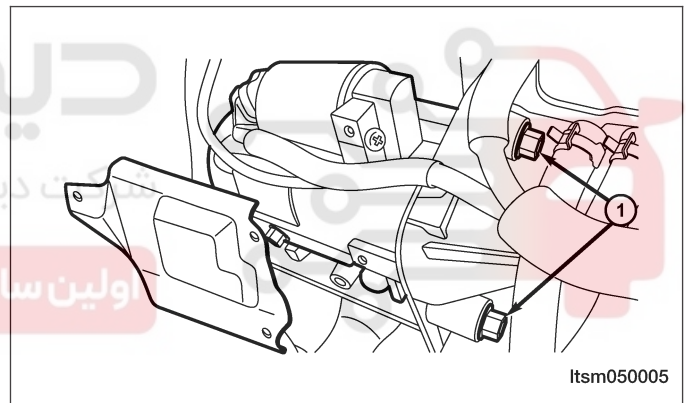

CHARGING SYSTEM

GENERAL INFORMATION	05-12	ON-VEHICLE SERVICE	05-17
Description	05-12	Generator	05-17
Operation	05-12	Removal & Installation - 1.6L & 1.8L & 2.0L	05-17
Specifications	05-13	Removal & Installation - 2.4L	05-18
Special Tools	05-13	Generator Inspection	05-18
Electrical Schematics	05-14		
DIAGNOSIS & TESTING	05-16		
Generator Noise	05-16		

دیجیتال خودرو

شرکت دیجیتال خودرو سامانه (مسئولیت محدود)

اولین سامانه دیجیتال تعمیرکاران خودرو در ایران



GENERAL INFORMATION

Description

1.6L & 1.8L & 2.0L

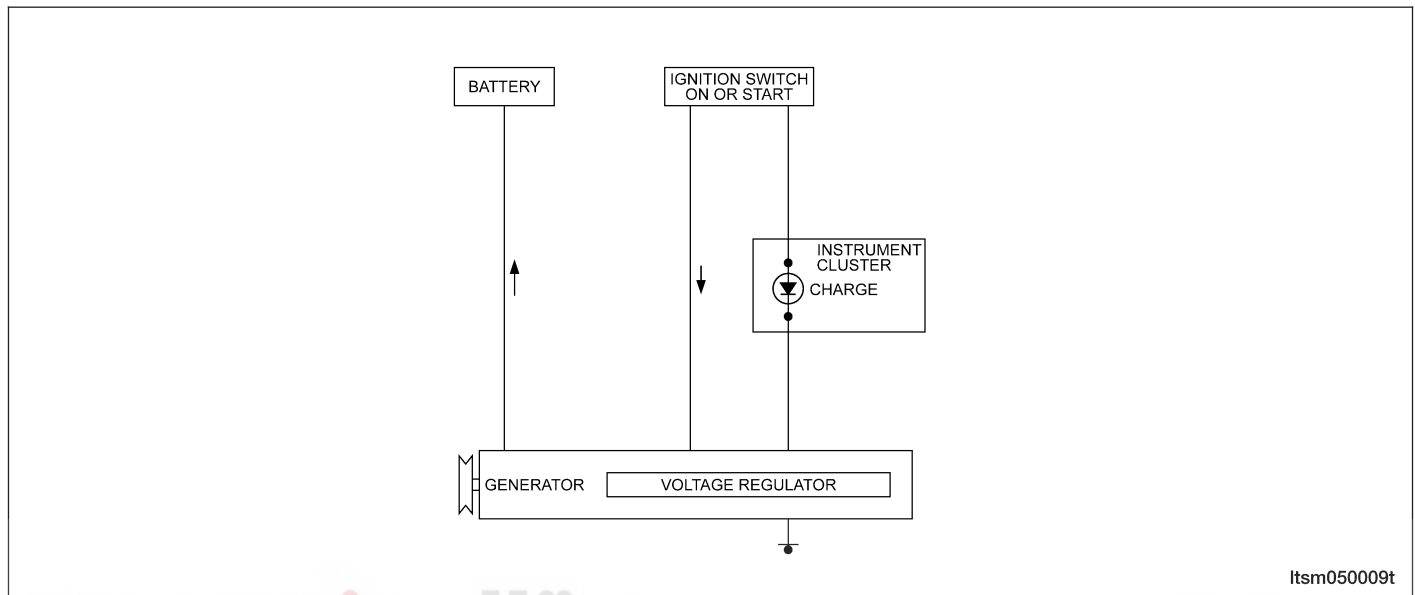

2.4L

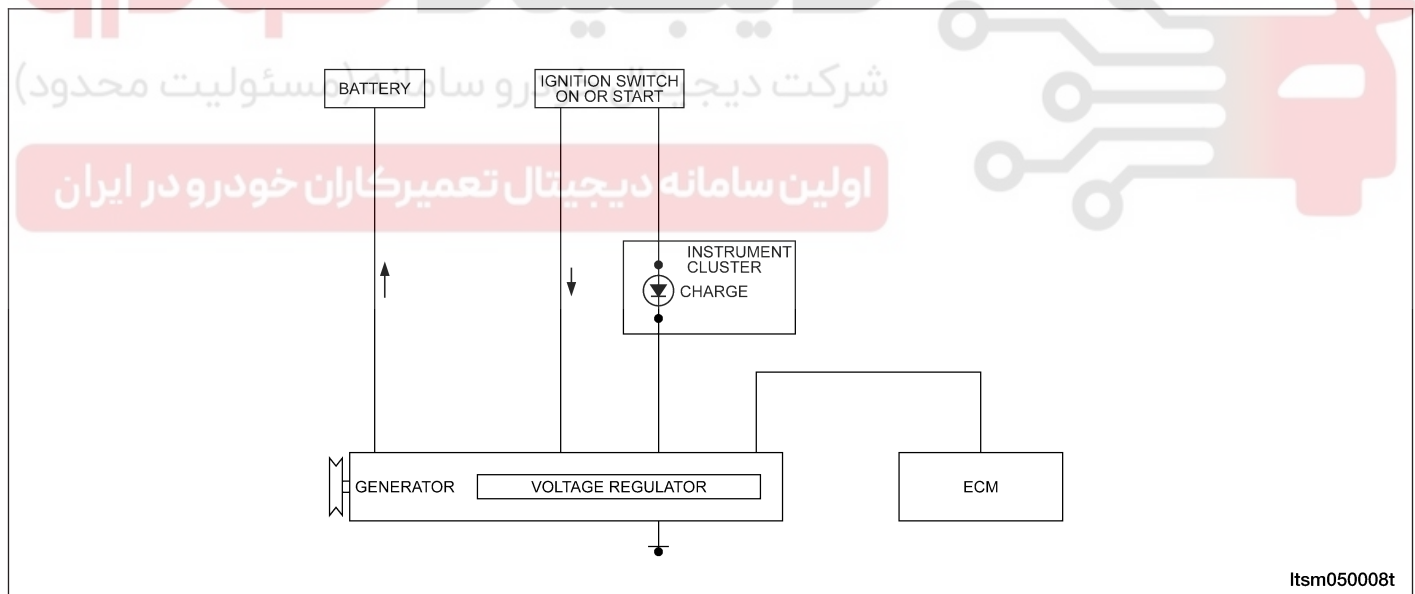

The generator is belt-driven by the engine. It is serviced only as a complete assembly. If the generator fails for any reason, the entire assembly must be replaced. The generator produces DC voltage.

Operation

As the energized rotor begins to rotate within the generator, the spinning magnetic field induces a current into the windings of the stator coil.

The Y-type stator winding connections deliver the induced AC current to 3 positive and 3 negative diodes for rectification. From the diodes, rectified DC current is delivered to the vehicle's electrical system through the generator, battery, and ground terminals.

GENERAL INFORMATION

Specifications

Torque Specifications

DESCRIPTION	TORQUE (N·m)
Generator Cable Nut	13
Generator Mounting Bolts	30
Generator Adjustment Bracket Bolts	25

Special Tools

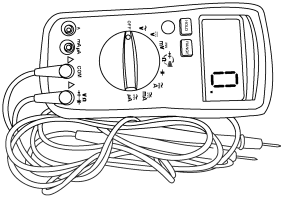
<p>Digital Multimeter Fluke 15B & 17B</p>	
---	---

05

دیجیتال خودرو

شرکت دیجیتال خودرو سامانه (مسئولیت محدود)

اولین سامانه دیجیتال تعمیرکاران خودرو در ایران



GENERAL INFORMATION

Electrical Schematics

Charging System (Page 1 of 2)

CHARGING SYSTEM - WITH MITSUBISHI ENGINE SYSTEM

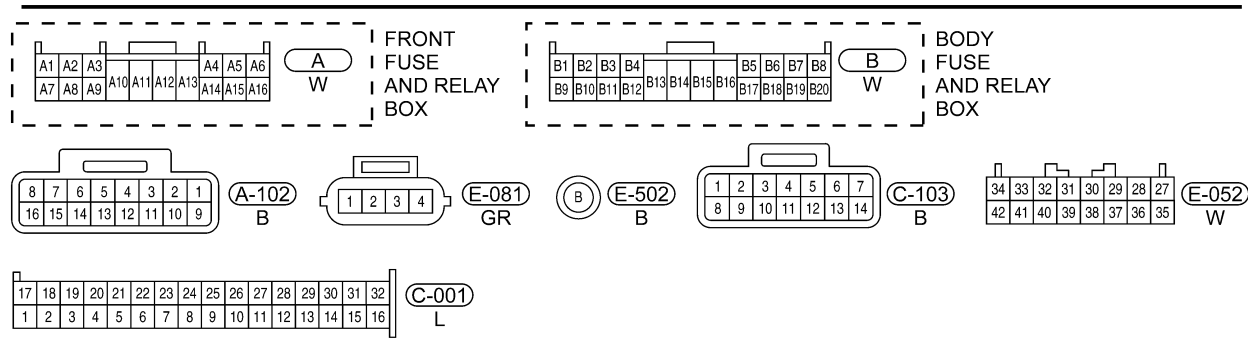
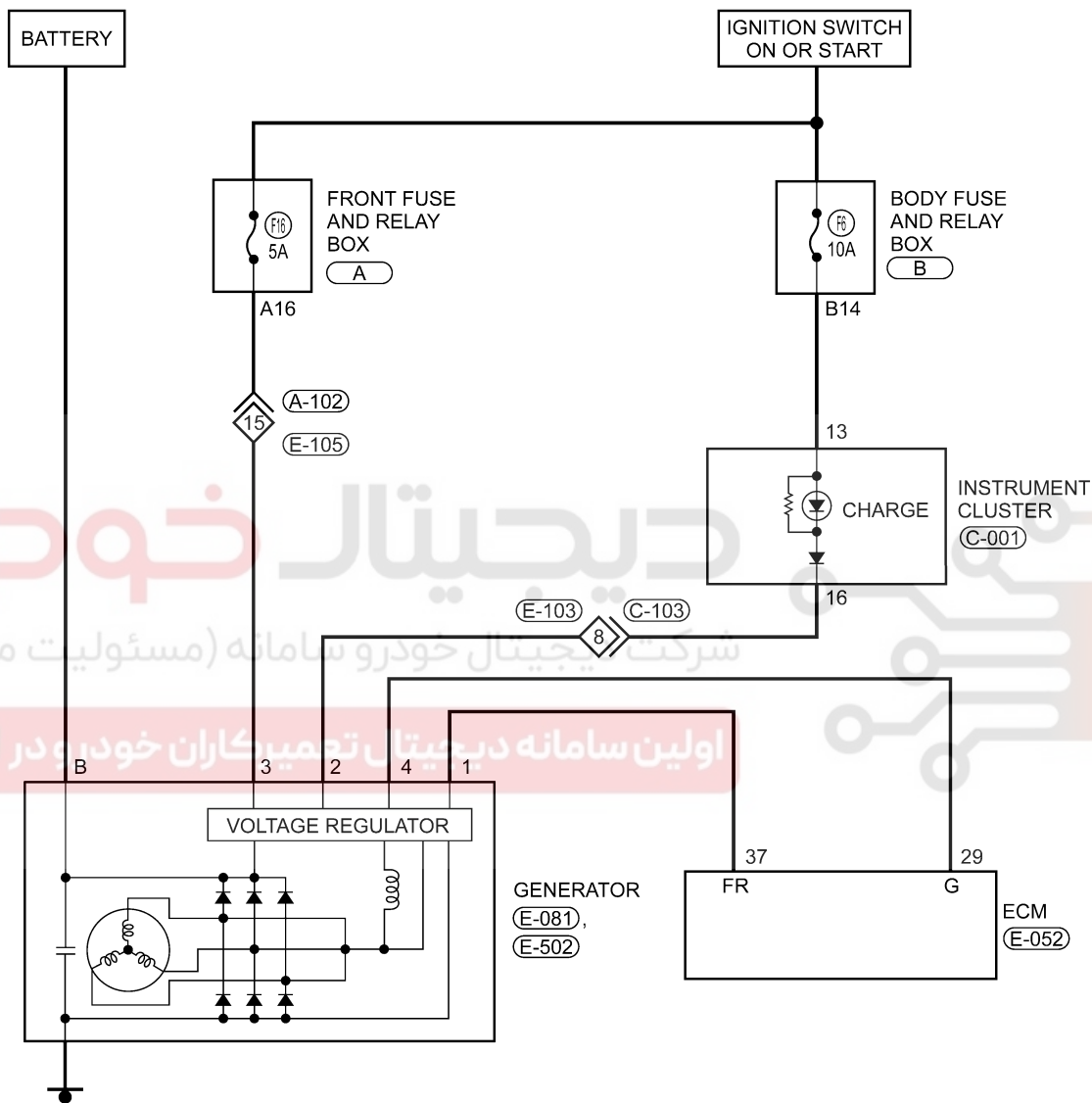

GENERAL INFORMATION

Charging System (Page 2 of 2)

CHARGING SYSTEM - WITH ACTECO ENGINE SYSTEM

- A1 : WITH ACTECO 1.6 - 1.8L ENGINE
- A2 : WITH ACTECO 2.0L ENGINE

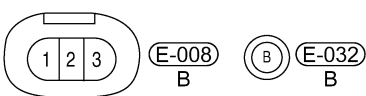
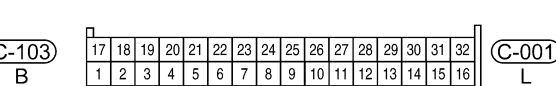
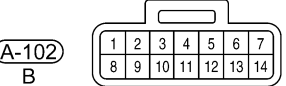
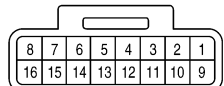
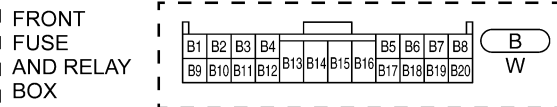
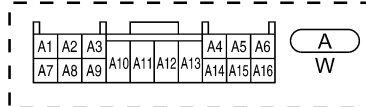
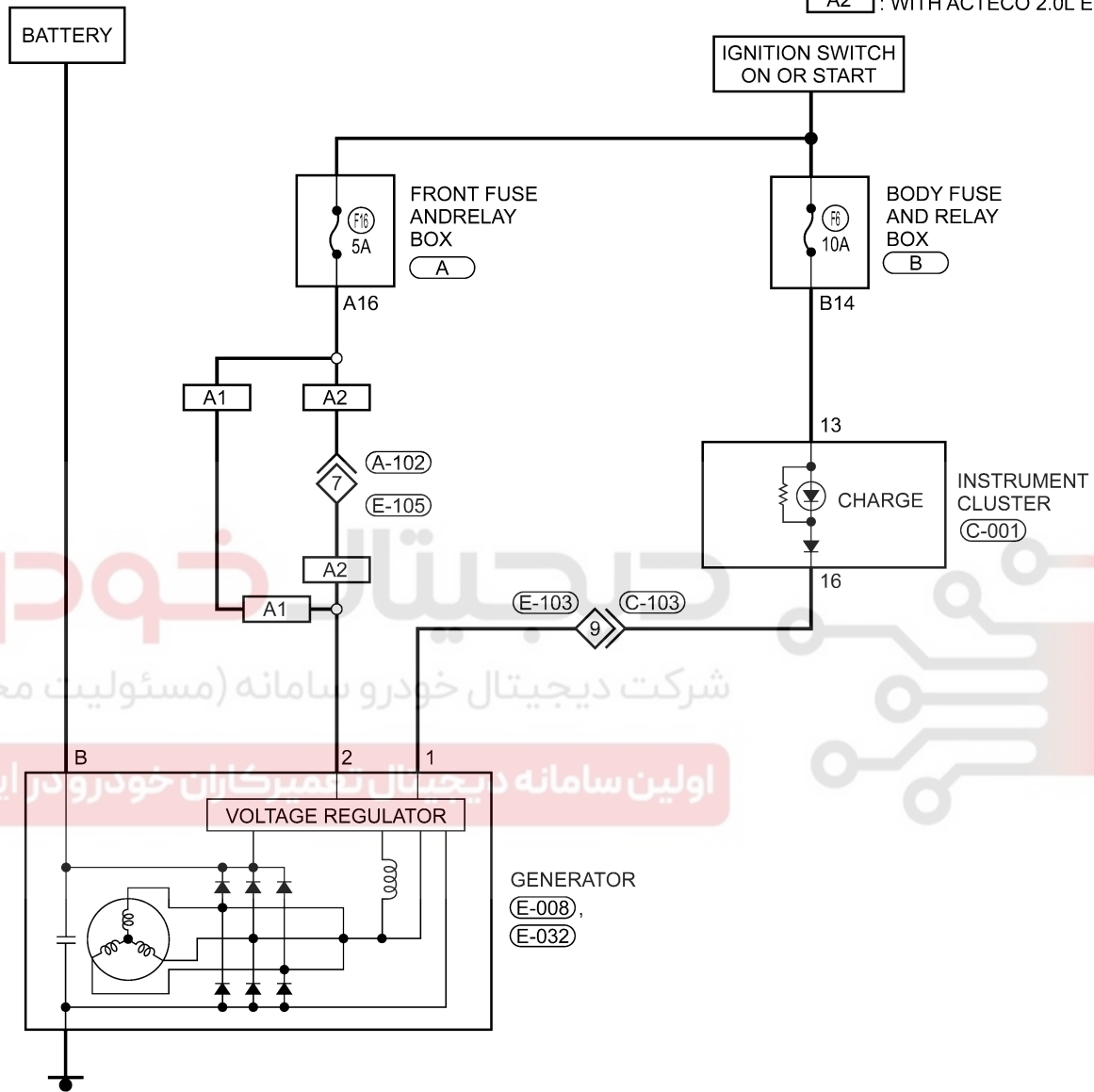

DIAGNOSIS & TESTING

Generator Noise

Noise emitting from the generator may be caused by the following:

- Worn, loose or defective bearings
- Loose or defective drive pulley
- Incorrect, worn, damaged or misadjusted drive belt
- Loose mounting bolts
- Misaligned drive pulley
- Defective stator
- Damaged internal fins

دیجیتال خودرو

شرکت دیجیتال خودرو سامانه (مسئولیت محدود)

اولین سامانه دیجیتال تعمیرکاران خودرو در ایران



ON-VEHICLE SERVICE

Generator

Removal & Installation - 1.6L & 1.8L & 2.0L

1. Disconnect the negative battery cable.
2. Disconnect the generator electrical connector.
3. Remove the engine drive belt (See Drive Belt Removal & Installation in Section 02 Engine).
4. Remove the generator cable nut (1) connecting the positive cable to the generator.
(Tighten: Generator cable nut to 13 N·m)

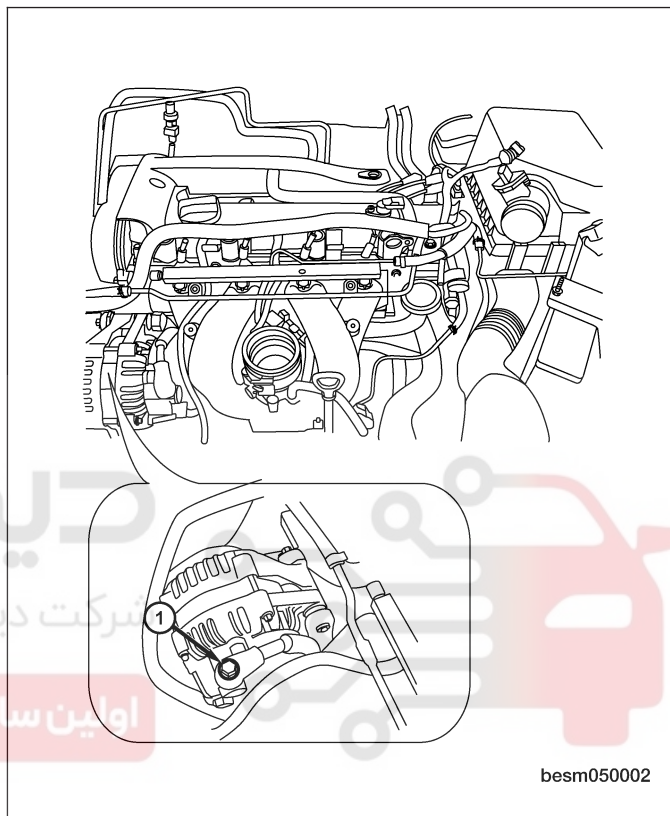

05

5. Remove two generator mounting bolts (1).
(Tighten: Generator mounting bolts to 30 N·m)
6. Remove the generator from the engine.
7. Installation is in the reverse order of removal.

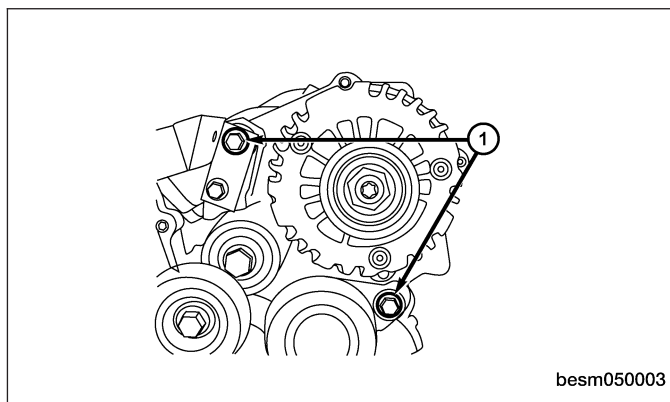

ON-VEHICLE SERVICE

Removal & Installation - 2.4L

1. Disconnect the negative battery cable.
2. Remove the engine drive belt (See Drive Belt Removal & Installation in Section 02 Engine).
3. Remove the generator cable nut (1) connecting the positive cable to the generator.
(Tighten: Generator cable nut to 10 N·m)
4. Disconnect the electrical connector (2).

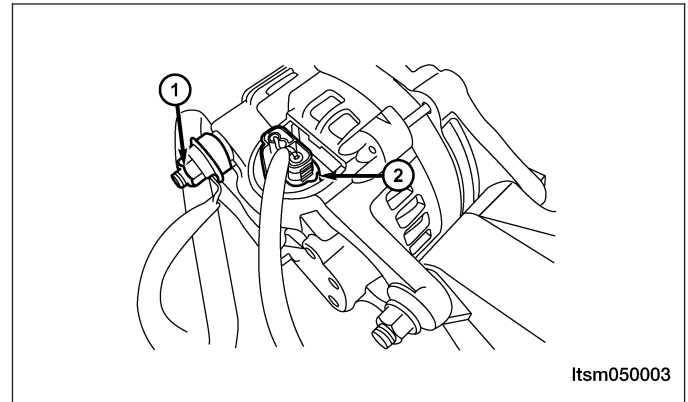

5. Remove the two generator adjustment bracket bolts (1).
(Tighten: Generator adjustment bracket bolts to 25 N·m)

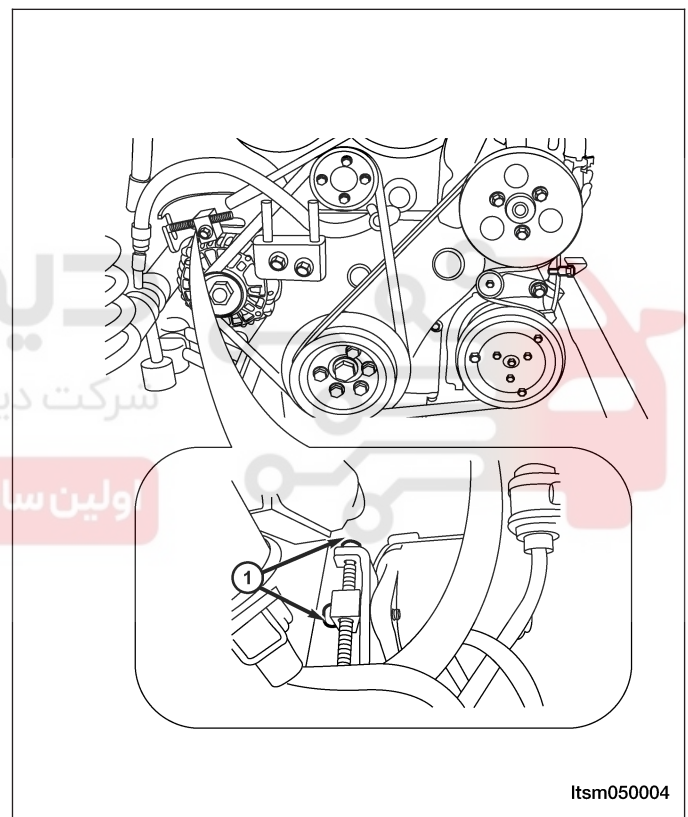

6. Remove the generator from the engine.
7. Installation is in the reverse order of removal.

Generator Inspection

1. Start the engine.
NOTE: If the battery warning lamp illuminates, there may be a problem with the charging system.
2. With the engine running, check the output voltage of the generator with a digital multimeter (note the voltage).
3. If the voltage is between 14.1 V - 14.7 V, the generator is good.